

Ruijie Reyee RG-EG400 Series Routers

Installation Guide

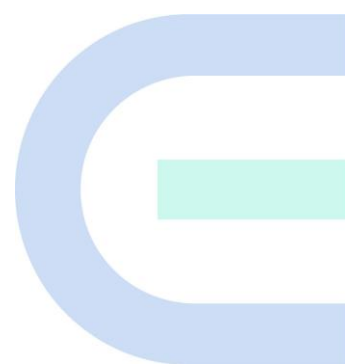

Copyright

Copyright © 2026 Ruijie Networks

All rights are reserved in this document and this statement.

Without the prior written consent of Ruijie Networks, any organization or individual shall not reproduce, extract, back up, modify, or propagate the content of this document in any manner or in any form, or translate it into other languages or use some or all parts of the document for commercial purposes.

 and other Ruijie networks logos are trademarks of Ruijie Networks.

All other trademarks or registered trademarks mentioned in this document are owned by their respective owners.

Disclaimer

The products, services, or features you purchase are subject to commercial contracts and terms, and some or all of the products, services, or features described in this document may not be available for you to purchase or use. Except for the agreement in the contract, Ruijie Networks makes no explicit or implicit statements or warranties with respect to the content of this document.

The names, links, descriptions, screenshots, and any other information regarding third-party software mentioned in this document are provided for your reference only. Ruijie Networks does not explicitly or implicitly endorse or recommend the use of any third-party software and does not make any assurances or guarantees concerning the applicability, security, or legality of such software. You should choose and use third-party software based on your business requirements and obtain proper authorization. Ruijie Networks assumes no liability for any risks or damages arising from your use of third-party software.

The content of this document will be updated from time to time due to product version upgrades or other reasons, Ruijie Networks reserves the right to modify the content of the document without any notice or prompt.

This manual is designed merely as a user guide. Ruijie Networks has tried its best to ensure the accuracy and reliability of the content when compiling this manual, but it does not guarantee that the content of the manual is completely free of errors or omissions, and all the information in this manual does not constitute any explicit or implicit warranties.

Preface

Intended Audience

This document is intended for:

- Network engineers
- Technical support and servicing engineers
- Network administrators

Technical Support

- Ruijie Reye website: <https://reyee.ruijie.com>
- Online support center: <https://reyee.ruijie.com/en-global/support>
- Case portal: <https://www.ruijie.com/support/caseportal>
- Community: <https://community.ruijienetworks.com>
- Email support: service_rj@ruijie.com
- Live chat: <https://reyee.ruijie.com/en-global/rita>

Conventions

1. Signs

This document also uses signs to indicate some important points during the operation. The meanings of these signs are as follows:

 **Danger**
An alert that calls attention to safety instruction that if not understood or followed can result in personal injury.

 **Warning**
An alert that calls attention to important rules and information that if not understood or followed can result in data loss or equipment damage.

 **Caution**
An alert that calls attention to essential information that if not understood or followed can result in function failure or performance degradation.

 **Note**
An alert that contains additional or supplementary information that if not understood or followed will not lead to serious consequences.

 **Specification**
An alert that contains a description of product or version support.

2. Note

This manual provides installation steps, troubleshooting, technical specifications, and usage guidelines for cables and connectors. It is intended for users who want to understand the above and have extensive experience in network deployment and management, and assume that users are familiar with related terms and concepts.

Contents

Preface	I
1 Overview	1
1.1 About the RG-EG400XS Series	1
1.2 Package Contents.....	1
1.2.1 RG-EG406XS-P	1
1.2.2 RG-EG406XS	2
1.3 Product Appearance	2
1.3.1 RG-EG406XS-P	2
1.3.2 RG-EG406XS	5
1.4 Technical Specifications	7
1.4.1 RG-EG406XS-P	7
1.4.2 RG-EG406XS	9
2 Preparing for Installation	11
2.1 Safety Precautions.....	11
2.1.1 General Precautions	11
2.1.2 Handling Safety.....	11
2.1.3 Electricity Safety	11
2.1.4 Preventing ESD Damage.....	12
2.2 Site Requirements	12
2.2.1 Floor Loading	12
2.2.2 Airflow.....	13
2.2.3 Space	13
2.2.4 Temperature and Humidity.....	13

2.2.5 Cleanliness.....	14
2.2.6 Grounding	14
2.2.7 EMI.....	15
2.2.8 Surge Protection	15
2.2.9 Installation Site.....	16
2.3 Rack Requirements	16
2.4 Notes for Connecting Optical Cables	17
2.5 Tools	17
3 Installing the Routers	18
3.1 Installation Procedure	18
3.2 Before You Begin.....	19
3.3 Precautions	19
3.4 Installing a Router	19
3.4.1 Mounting the Router into a Rack	20
3.4.2 Mounting the Router on a Workbench.....	22
3.5 Connecting the Grounding Wire	22
3.6 Connecting the Power Cord.....	23
3.7 Connecting Cables.....	23
3.8 Bundling Cables.....	23
3.8.1 Precautions	23
3.8.2 Bundling Steps.....	23
3.9 Verifying Installation.....	24
3.9.1 Verifying the Equipment.....	24
3.9.2 Verifying Cable Connection	24

3.9.3 Verifying Power Supply	24
4 Verifying Operating Status	25
4.1 Setting up Configuration Environment.....	25
4.2 Checklist.....	25
4.2.1 Checklist before Power-on.....	25
4.2.2 Checklist after Power-on.....	25
4.3 Log In to the Web Interface	26
5 Troubleshooting.....	27
5.1 General Troubleshooting Procedure	27
5.2 Common Troubleshooting Procedures.....	27
5.2.1 Password Loss.....	27
5.2.2 System LED Error	27
6 Appendix.....	28
6.1 Connectors and Media.....	28
6.1.1 10/100/1000/2500BASE-T Port	28
6.2 Mini-GBIC and 10GE SFP+ Module Specifications	29
6.3 Cabling Recommendations.....	36

1 Overview

1.1 About the RG-EG400XS Series

The RG-EG400XS series routers are data communications products independently developed by Ruijie Networks, with full ownership of intellectual property rights. The high-performance egress routers are suitable for medium and large hotels, residential communities, HQ-branch enterprises, and chain businesses. With a recommended egress bandwidth of 2500 Mbps, they meet high-bandwidth demands and can support up to 400 concurrent users. The RG-EG400XS series routers offer flexible multi-WAN and policy-based routing features, comprehensive online behavior management policies, and user-friendly, high-performance VPN bonding features. As the primary devices of a self-organizing network, the routers can work with managed switches and wireless access points (APs) to achieve network-wide centralized configuration. They support remote network management and troubleshooting via a dedicated mobile app.

Table 1-1 RG-EG400XS Series Specifications

Model	10/100/1000/2500BASE-T Port	10G SFP+ Port	PoE Port	Power Supply
RG-EG406XS-P	5 (1 x fixed LAN port, 1 x fixed WAN port, 3 x LAN/WAN ports)	1 (1x LAN/WAN port)	4	Power adapter
RG-EG406XS	5 (1 x fixed LAN port, 1 x fixed WAN port, 3 x LAN/WAN ports)	1 (1x LAN/WAN port)	/	Power adapter

1.2 Package Contents

1.2.1 RG-EG406XS-P

Table 1-2 Package Contents

No.	Item	Quantity
1	RG-EG406XS-P router	1
2	Power adapter	1
3	Rubber pad	4
4	Power cord	1
5	User Manual	1
6	Warranty Card	1

1.2.2 RG-EG406XS

Table 1-3 Package Contents

No.	Item	Quantity
1	RG-EG406XS router	1
2	Power adapter	1
3	Rubber pad	4
4	Rack-mount bracket	2
5	User Manual	1
6	Warranty Card	1
7	M3 x 6 mm cross recessed countersunk head screws	6

1.3 Product Appearance

1.3.1 RG-EG406XS-P

Figure 1-1 RG-EG406XS-P Appearance

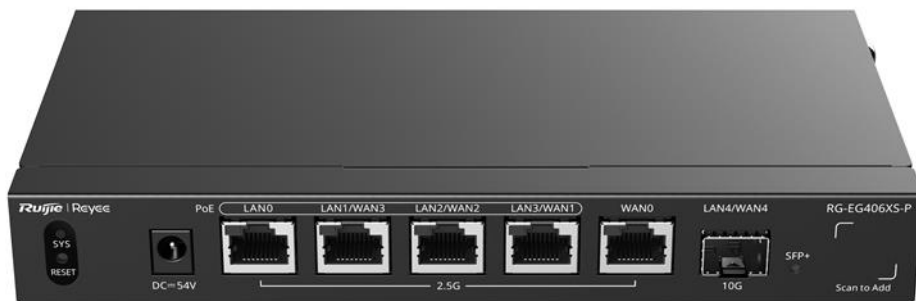

Note

This image is for reference only. The actual product may vary.

Figure 1-2 Front Panel

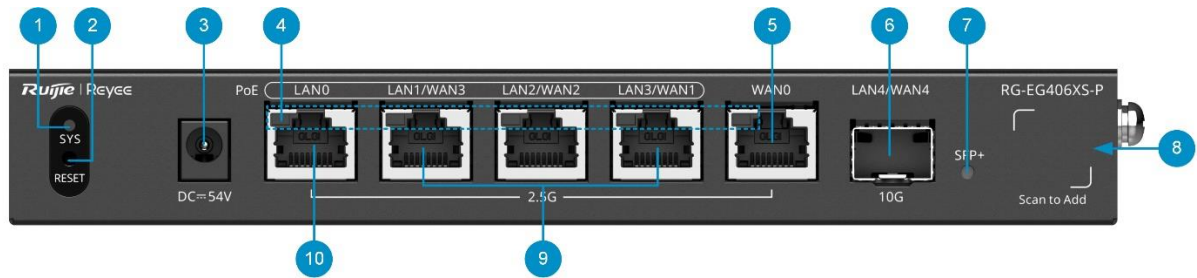

Table 1-4 Front Panel System Status LED Description

No.	Silkscreen	Item	Description
1	SYS	System status LED	Off: The device is not powered on.
			Solid green: The device has successfully completed startup and is operating normally.
			Fast green blinking: The device is starting up.
			Slow green blinking: Restoring factory settings or upgrading firmware.
			Solid green with brief off intervals: Device not connected to Ruijie Cloud.
			One long red blink followed by three slow blinks: Main program is missing.
			One long yellow blink followed by one slow blink: PoE power overload or insufficient power supply to the device.
System status LED blinking frequency description:			
<ul style="list-style-type: none"> ● Fast blinking: Blink eight times per second. ● Slow blinking: Blink twice per second. ● Long blinking: Blink once every two seconds. ● Solid with brief off intervals: One long on and one short off every two seconds. 			

Table 1-5 Components on the Front Panel

No.	Component	Description
2	Reset button	Used to restart the device or reset the device to factory settings. <ul style="list-style-type: none"> ● Press and hold the button for less than 2 seconds: The device restarts. ● Press and hold the button for more than 5 seconds until the system status LED starts blinking: The device restores to factory defaults and restarts.

No.	Component	Description
3	DC input plug	Connects to the DC power adapter to power on the router.
4	Link/ACT LED for an RJ45 port	Indicates the working status of the RJ45 port. <ul style="list-style-type: none"> ● Solid green: A link is set up on the port. ● Blinking green: The port is transmitting and receiving data.
5	WAN port	Indicates a 10/100/1000/2500BASE-T port connected to a Digital Subscriber Line (DSL) or cable modem for Internet access.
6	LAN/WAN optical port	Indicates a 10GE SFP+ port, which can be used as a WAN port.
7	Link/ACT LED for the optical port	Indicates the working status of the optical port. <ul style="list-style-type: none"> ● Solid green: A link is set up on the port. ● Blinking green: The port is transmitting and receiving data.
8	QR code	Scan the QR code to download the dedicated app.
9	LAN/WAN port	LAN1 to LAN3 are 10/100/1000/2500BASE-T ports and can be used as WAN ports.
10	LAN port	LAN0 is a 10/100/1000/2500BASE-T port and is a fixed LAN port.

Note

After the router is reset, the default management address is <http://192.168.110.1> (default password: admin).

Figure 1-3 Bottom View

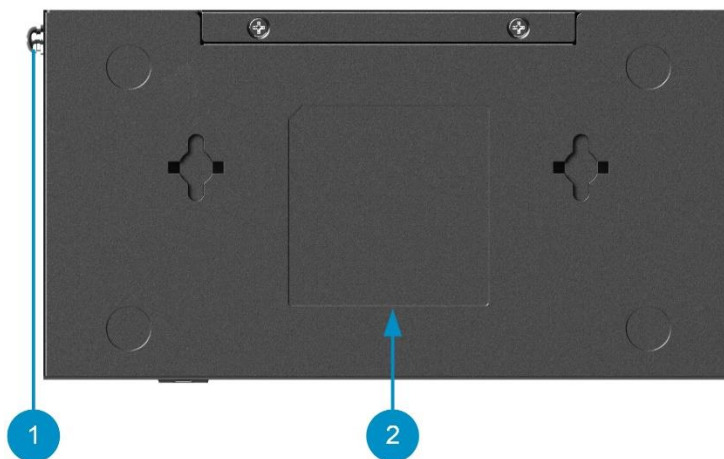

Table 1-6 Other Components

No.	Item	Description
1	Grounding	Connects to the terminal of a grounding wire to ground the chassis.

No.	Item	Description
	stud	
2	Label	Contains the product name, model, I/O parameters, default IP address, etc.

1.3.2 RG-EG406XS

Figure 1-4 RG-EG406XS Appearance



Figure 1-5 Front Panel

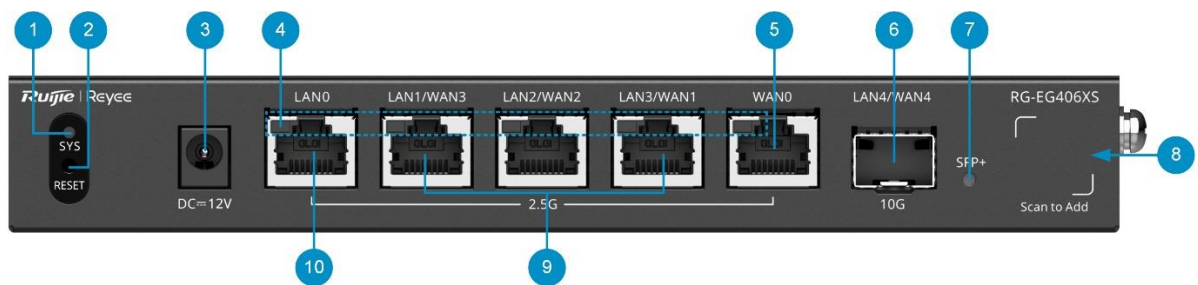

Table 1-7 Front Panel System Status LED Description

No.	Silkscreen	Item	Description
1	SYS	System status LED	Off: The device is not powered on.
			Solid green: The device has successfully completed startup and is operating normally.

No.	Silkscreen	Item	Description
			Fast green blinking: The device is starting up.
			Slow green blinking: Restoring factory settings or upgrading firmware.
			Solid green with brief off intervals: Device not connected to Ruijie Cloud.
			One long red blink followed by three slow blinks: Main program is missing.
<p>System status LED blinking frequency description:</p> <ul style="list-style-type: none"> ● Fast blinking: Blink eight times per second. ● Slow blinking: Blink twice per second. ● Long blinking: Blink once every two seconds. ● Solid with brief off intervals: One long on and one short off every two seconds. 			

Table 1-8 Components on the Front Panel

Mark	Item	Description
2	Reset button	<p>Used to restart the device or reset the device to factory settings.</p> <ul style="list-style-type: none"> ● Press and hold the button for less than 2 seconds: The device restarts. ● Press and hold the button for more than 5 seconds until the system status LED starts blinking: The device restores to factory defaults and restarts.
3	DC input plug	Connects to the DC power adapter to power on the router.
4	Link/ACT LED for an RJ45 port	<p>Indicates the working status of the RJ45 port.</p> <ul style="list-style-type: none"> ● Solid green: A link is set up on the port. ● Blinking green: The port is transmitting and receiving data.
5	WAN port	Indicates a 10/100/1000/2500BASE-T port connected to a DSL or cable modem for Internet access.
6	LAN/WAN optical port	Indicates a 10GE SFP+ port, which can be used as a WAN port.
7	Link/ACT LED for the optical port	<p>Indicates the working status of the optical port.</p> <ul style="list-style-type: none"> ● Solid green: A link is set up on the port. ● Blinking green: The port is transmitting and receiving data.
8	QR code	Scan the QR code to download the dedicated app.
9	LAN/WAN port	LAN1 to LAN3 are 10/100/1000/2500BASE-T ports and can be used as WAN ports.
10	LAN port	LAN0 is a 10/100/1000/2500BASE-T port and is a fixed LAN port.

Note

After the router is reset, the default management address is <http://192.168.110.1> (default password: admin).

Figure 1-6 Label of RG-EG406XS

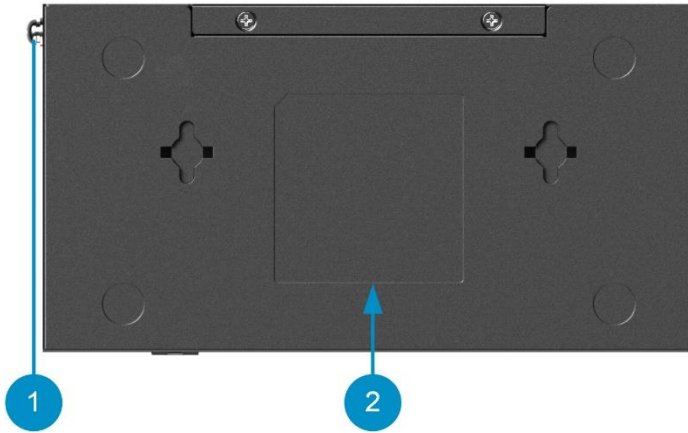

Table 1-9 Other Components

Mark	Item	Description
1	Grounding stud	Connects to the terminal of a grounding wire to ground the chassis.
2	Label	Contains the product name, model, I/O parameters, default IP address, etc.

1.4 Technical Specifications

1.4.1 RG-EG406XS-P

Table 1-10 Technical Specifications

Model	RG-EG406XS-P
CPU	Quad-core processor, 2 GHz clock frequency per core
Flash Memory	256 MB
SDRAM	1 GB DDR4
Fixed Service Port	5 x 10/100/1000/2500BASE-T ports 1 x 10GE SFP+ port By default, LAN0 to LAN4 are LAN ports, while WAN0 is a WAN port. LAN1 to LAN4 can be used as WAN ports.

Power Supply	<p>DC adapter:</p> <p>Rated input voltage: 100 V AC to 240 V AC, 50 Hz to 60 Hz</p> <p>Maximum input voltage: 90 V AC to 264 V AC, 47 Hz to 63 Hz (optional)</p> <p>Rated input current: 2.5 A</p> <p>Output:</p> <p>Rated output voltage: 54 V DC</p> <p>Maximum output current: 2.4 A</p>
Dimensions of the DC Connector	<p>Inner diameter: 2.1 mm (0.08 in.)</p> <p>Outer diameter: 5.5 mm (0.22 in.)</p> <p>Depth: 10.0 mm (0.39 in.)</p>
Ground-Leakage Current	≤ 3.5 mA
EEE	Supported
PoE	Supported
PoE Out Standard	IEEE 802.3af (PoE) and IEEE 802.3at (PoE+)
PoE Budget	110 W
Max. Power Consumption	<p>9.2 W (with no PoE load)</p> <p>129 W (with full PoE load)</p>
Operating Temperature	0°C to 40°C (32°F to 104°F)
Storage Temperature	-40°C to +70°C (-40°F to +158°F)
Operating Humidity	10% RH to 90% RH (non-condensing)
Storage Humidity	5% RH to 95% RH (non-condensing)
Fan	N/A
IP Rating	IP20
Certification	CE
Dimensions (W x D x H)	202 mm x 108 mm x 28 mm (7.95 in. x 4.25 in. x 1.1 in.)
Weight	0.62 kg (1.37 lbs)
Shipping Weight	1.56 kg (3.44 lbs)

 **Warning**

- This is a Class A product. The equipment room should be located away from residential areas. Equipment rooms near residential areas should meet construction specifications to avoid noise and radio interference.
 - This equipment is not suitable for use in locations where children are likely to be present.
-

1.4.2 RG-EG406XS

Table 1-11 Technical Specifications

Model	RG-EG406XS
CPU	Quad-core processor, 2 GHz clock frequency per core
Flash Memory	256 MB
SDRAM	1 GB DDR4
Fixed Service Port	5 x 10/100/1000/2500BASE-T ports 1 x 10GE SFP+ port By default, LAN0 to LAN4 are LAN ports, while WAN0 is a WAN port. LAN1 to LAN4 can be used as WAN ports.
Power Supply	DC adapter: Rated input voltage: 100 V AC to 240 V AC, 50 Hz to 60 Hz Maximum input voltage: 90 V AC to 264 V AC, 47 Hz to 63 Hz (optional) Rated input current: 0.5 A Output: Rated output voltage: 12 V DC Maximum output current: 1 A
Dimensions of the DC Connector	Inner diameter: 2.1 mm (0.08 in.) Outer diameter: 5.5 mm (0.22 in.) Depth: 10.0 mm (0.39 in.)
Ground-Leakage Current	≤ 3.5 mA
EEE	Supported
PoE	Not Supported
Max. Power Consumption	9 W
Operating Temperature	0°C to 40°C (32°F to 104°F)
Storage Temperature	−40°C to +70°C (−40°F to +158°F)
Operating Humidity	10% RH to 90% RH (non-condensing)
Storage Humidity	5% RH to 95% RH (non-condensing)
Fan	N/A
IP Rating	IP20

Certification	CE
Dimensions (W x D x H)	202 mm x 108 mm x 28 mm (7.95 in. x 4.25 in. x 1.1 in.)
Weight	0.61 kg (1.34 lbs)
Shipping Weight	1.28 kg (2.82 lbs)

 **Warning**

- This is a Class A product. The equipment room should be located away from residential areas. Equipment rooms near residential areas should meet construction specifications to avoid noise and radio interference.
 - This equipment is not suitable for use in locations where children are likely to be present.
-

2 Preparing for Installation

2.1 Safety Precautions

Note

- The equipment mentioned in this manual cannot be mounted on a wall.
 - To avoid personal injury or equipment damage, review the safety guidelines in this chapter before you begin the installation.
 - The following safety guidelines may not include all the potentially hazardous situations.
-

2.1.1 General Precautions

- Do not place the equipment in a wet position, and keep the equipment away from liquid. Keep the chassis clean and dust-free.
- Install the equipment in a position far away from heat sources.
- Ensure that the rack and power distribution system are properly grounded.
- Keep the equipment away from walk areas.
- During installation and maintenance, do not wear loose clothing or ornament that may get caught in the chassis.
- Keep tools and components away from walking areas.

2.1.2 Handling Safety

- Avoid moving the equipment frequently.
- Turn off all power supplies and disconnect all power cords before lifting or moving the equipment.
- Keep balance and prevent personal injuries when lifting or moving the equipment.

2.1.3 Electricity Safety

Warning

- Any deviation from standard or improper electrical operations can result in accidents such as fires or electric shocks, potentially causing severe or even fatal harm to both individuals and equipment.
 - Direct or indirect touch through a wet object on high-voltage and mains supply can bring a fatal danger.
-
- Always observe the local regulations and standards. Only qualified personnel should be allowed to operate the equipment.
 - Carefully check the work area for potential hazards, including ungrounded power system, absent safety grounds, and damp floors.
 - Locate the emergency power-off switch in the room before installation. In the case of an accident, cut off the power supply immediately.
 - Do not assume that the power supply is turned off. Never assume that power is disconnected from a circuit. Always check.

- Select the right leakage protector (also called “leakage current switch” or “leakage current breaker”) for the power supply system. This equipment automatically disconnects the power supply in the event of leakage and the risk of electric shock. A leakage protector should meet the following requirements:

- The rated leakage action current of each leakage protector is greater than twice the theoretical maximum leakage current of all the power supplies in the system.

For example, if a system is equipped with 16 identical power supplies, and the leakage current of each power supply is equal to or less than 3.5 mA, then the leakage current of the system totals 56 mA. A leakage protector with a rated leakage action current of 30 mA supports no more than four power supplies (that is, action current of the leakage protector/2/Maximum leakage current of each power supply = $30/2/3.5 \approx 4.28$). In this case, 16 power supplies in the system require at least four leakage protectors with a rated action current of 30 mA, with each leakage protector supporting four power supplies.

- Although the number of power supplies in a system differs in models, the rated leakage action current of each leakage protector divided by two must be greater than the sum of the maximum leakage current of all the power supplies.

The rated leakage non-action current of a leakage protector should be 50% of the leakage action current. If the non-action current value is too small, the high sensitivity level can cause the circuit to break, leading to power cutoff and service interruption, even if the leakage current value is normal.

For example, if a leakage protector has a rated leakage action current of 30 mA, the rated leakage non-action current should be 15 mA. The leakage protector will not activate unless the leakage current exceeds 15 mA.

 **Caution**

- To ensure personal safety, each leakage protector in the system must have a rated leakage action current equal to or below 30 mA, which is the recognized safety threshold for the human body current. If the total leakage current of the system exceeds twice the 30 mA limit, the system must be equipped with two or more leakage protectors to maintain safety.
 - The leakage current values vary with equipment. For the leakage current value of each equipment model, see the technical specifications in Chapter 1.
-

2.1.4 Preventing ESD Damage

- Ensure proper grounding of both the equipment and the installation site.
- Keep the site as dust-free as possible.
- Maintain appropriate humidity conditions.

2.2 Site Requirements

The equipment must be installed indoors for normal operation and prolonged service life. The installation site must meet the following requirements.

2.2.1 Floor Loading

Assess the combined weight of the equipment and its accessories, such as rack and cables, and verify that the floor under the rack can bear the weight.

If the RG-EG406XS router is installed inside a rack, the following conditions must be met:

- Install the router into an open rack. If the router is installed into a closed rack, ensure that the rack has proper ventilation and heat dissipation.
- The rack is strong enough to support the weight of the router and its accessories.
- You are advised to install the equipment into a standard rack and maintain a proper clearance around the air vents for heat dissipation.
- The rack is properly grounded.

To install the equipment on a workbench, make sure that the workbench meets the following conditions:

- The size of the workbench is suitable and a proper clearance can be maintained around the air vents for heat dissipation.
- The workbench must be properly grounded.

2.2.2 Airflow

Maintain a minimum clearance of 100 mm (3.94 in.) around the equipment for air circulation and normal heat dissipation. After various cables are connected, bundle the cables or place them in the cable management bracket to avoid blocking air inlets. Dust the equipment every three months to avoid blocking the ventilation openings.

2.2.3 Space

You are advised to have a pathway of 0.8 meters (2.62 ft.) wide in the equipment room. This space ensures that you can move the chassis and swap the modules easily.

Do not install the equipment against a wall. Instead, maintain a minimum clearance of 0.4 m (15.75 in.) around the equipment for heat dissipation and equipment maintenance.

2.2.4 Temperature and Humidity

To ensure normal operation and prolonged service life of the equipment, maintain appropriate temperature and humidity conditions in the equipment room.

Prolonged exposure to inappropriate temperature and humidity conditions can cause damage to the equipment.

- In an environment with high relative humidity, insulating materials are prone to poor insulation or even electricity leakage.
- In an environment with low relative humidity, insulating gaskets may shrink, resulting in screw loosening.
- In a dry environment, static electricity is more likely to occur, posing a risk to the internal circuits of equipment.
- A high temperature can accelerate the aging process of insulation materials, greatly reducing the availability of the equipment and severely affecting its service life.

The temperature and humidity requirements of the equipment are as follows:

Table 2-1 Operating Environment Requirements

Operating Temperature	Operating Humidity
0°C to 40°C (32°F to 104°F)	10% RH to 90% RH (non-condensing)

Note

The operating temperature and humidity are measured at 1.5 m (4.92 ft.) above the floor and 0.4 m (1.31 ft.) before the rack when there is no protective plate in front or on the rear of the rack.

2.2.5 Cleanliness

Dust poses a significant hazard to the equipment. Dust on the enclosure causes electrostatic adhesion, leading to poor contact with the metallic joints. Electrostatic adhesion is more likely to occur in an indoor environment with relatively low humidity, not only affecting the service life of the equipment, but also causing communication faults. The following table lists the requirements for dust concentration and particle size in the equipment room.

Table 2-2 Requirements for Dust

Particle Diameter	Unit	Concentration
≥ 0.5 μm	Particles/m ³	≤ 3.5 x 10 ⁶
≥ 5 μm	Particles/m ³	≤ 3 x 10 ⁴

Apart from dust, there are also requirements on the salt, acid, and sulfide in the air of the equipment room. These harmful substances will accelerate metal corrosion and component aging. Therefore, the equipment room should be properly protected against harmful gases, such as sulfur dioxide, hydrogen sulfide, nitrogen dioxide, chlorine gas, and so on. The following table lists the limits on harmful gases.

Table 2-3 Requirements for Gases

Gas	Average (mg/m ³)	Maximum (mg/m ³)
Sulfur dioxide (SO ₂)	0.3	1.0
Hydrogen sulfide (H ₂ S)	0.1	0.5
Nitrogen dioxide (NO ₂)	0.5	1.0
Chlorine gas (Cl ₂)	0.1	0.3

Note

Average refers to the average value of harmful gases measured in a week. **Maximum** refers to the upper limit of harmful gases measured in a week for up to 30 minutes every day.

2.2.6 Grounding

A proper grounding system is crucial for ensuring stable and reliable operation, as well as preventing lightning strikes and interference. Carefully check the grounding conditions at the installation site according to the grounding requirements, and complete grounding properly based on the site situation.

- Safe Grounding

Ensure that the equipment is securely grounded using grounding wires if the equipment uses the AC power supply. Otherwise, electric shocks may occur when the insulation resistance between the power module and the chassis decreases.

⚠ Caution

- The building should provide a protective ground connection to ensure that the equipment is connected to a protective ground.
 - Verify that the AC socket is reliably connected to the protective grounding system of the building. If not, a protective grounding wire should be used to connect the protective grounding lug of the AC socket to the protective grounding system of the building.
 - The cross-sectional area of the protective grounding wire should be at least 0.75 mm² (18 AWG).
-

- **Lightning Grounding**

The lightning protection system is an independent system composed of a lightning rod, a downlead conductor, and a connector connected to the grounding system. The grounding system is typically used for power reference grounding and safety grounding of the rack. Lightning grounding is required only for facilities and is not required for the equipment.

- **EMC Grounding**

Electromagnetic compatibility (EMC) grounding includes shielded grounding, filter grounding, noise and interference suppression, and level reference, which contribute to the overall grounding requirements. The grounding resistance should be smaller than 1 ohm. Connect the grounding lug to the ground before operating the equipment.

2.2.7 EMI

All interference sources, either from outside or inside of the equipment or application system, affect the equipment by capacitive coupling, inductive coupling, or electromagnetic waves. Electromagnetic interference (EMI) occurs due to radiated interference or conducted interference, depending on the transmission path. When the energy, often RF energy, from a component arrives at a sensitive component through space, the energy is known as radiated interference. The interference source can be either a part of the interfered system or a completely electrically isolated unit. Conducted interference occurs when interference is transferred from one unit to another unit through cables, which are usually electromagnetic wires or signal cables connected between the source and the sensor. Conducted interference often affects the power supply of the equipment, but can be controlled by a filter. Radiated interference may affect any signal path in the equipment, and is difficult to shield.

The requirements for the equipment anti-interference are as follows:

- Take interference prevention measures for the power supply system.
- Keep the switch away from the grounding system or surge protection grounding system of the power facility.
- Keep the equipment far away from high-frequency current equipment such as high-power radio transmitting stations and radar stations.
- Take electromagnetic shielding measures when necessary.

2.2.8 Surge Protection

Although the equipment can guard against lightning strikes, strong lightning strikes may still damage the equipment. Take the following surge protection measures:

- Ensure that the grounding wire of the rack is in good contact with the ground.
- Ensure that the neutral point of the AC power socket is in good contact with the ground.
- Install a power lightning arrester in front of the power input end to enhance surge prevention for the power supply.

2.2.9 Installation Site

Regardless of whether the equipment is installed in a rack or on a workbench, ensure that the following conditions are met:

- Maintain a proper clearance around the air inlets and outlets for heat dissipation.
- The installation site has a good cooling and ventilation system.
- The installation site is sturdy enough to support the weight of the chassis and its components.
- The installation site is properly grounded.

2.3 Rack Requirements

If you want to install the equipment in a rack, make sure that the rack observes the following requirements:

- (1) A standard 19-inch rack is used.
- (2) The left and right square-hole rack posts are 465 mm (18.31 in.) apart.

Figure 2-1 19-inch Rack

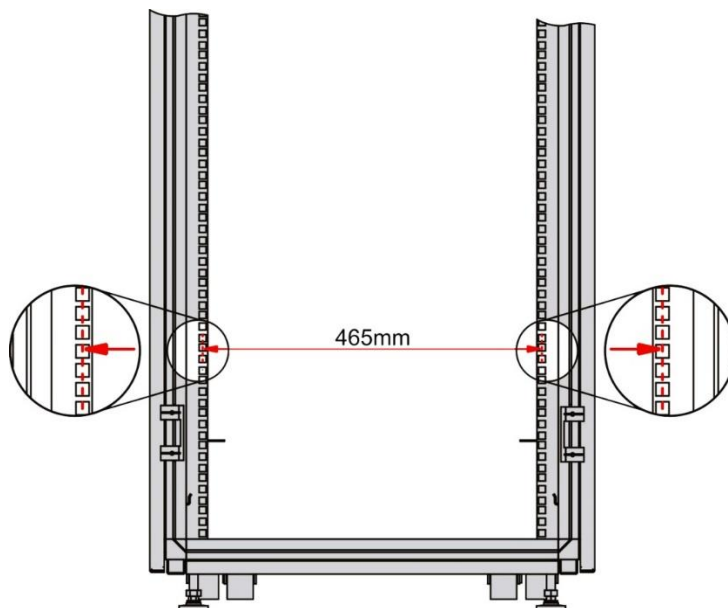

- (3) The square-hole rack post is at least 180 mm (7.09 in.) from the front door, and the front door is at most 25 mm (0.98 in.) thick. This ensures an available clearance of at least 155 mm (6.10 in.). The rack depth (distance between front and rear doors) is at least 1000 mm (39.37 in.).
- (4) The guide rails or tray can bear the weight of the equipment and its accessories.
- (5) The rack has a reliable grounding lug for the chassis to connect to earth ground.
- (6) The rack has a reliable ventilation system. The open area of front and rear doors is greater than 50%.

2.4 Notes for Connecting Optical Cables

Before connecting the optical cables, verify that the fiber connector type and fiber type match the optical port type. Attention should also be paid to the Rx and Tx ends of an optical cable. The Tx end of the local device must be connected to the Rx end of the peer device, and vice versa.

2.5 Tools

Table 2-4 Tools

Common Tools	Phillips screwdriver, power cords, Ethernet cables, fastening bolts, diagonal pliers, and binding straps
Dedicated Tools	Anti-ESD gloves, wire stripper, crimping pliers, crystal connector crimping pliers, and wire cutter
Meter	Multimeter
Relevant Equipment	PC, display, and keyboard

 **Note**

The equipment is delivered without a toolkit. Prepare the preceding tools by yourself.

3 Installing the Routers

⚠ Caution

Before installing the equipment, ensure that guidelines and requirements in Chapter 2 have been met.

3.1 Installation Procedure

The installation steps are shown in the following figure.

Table 3-1 Installation Procedure

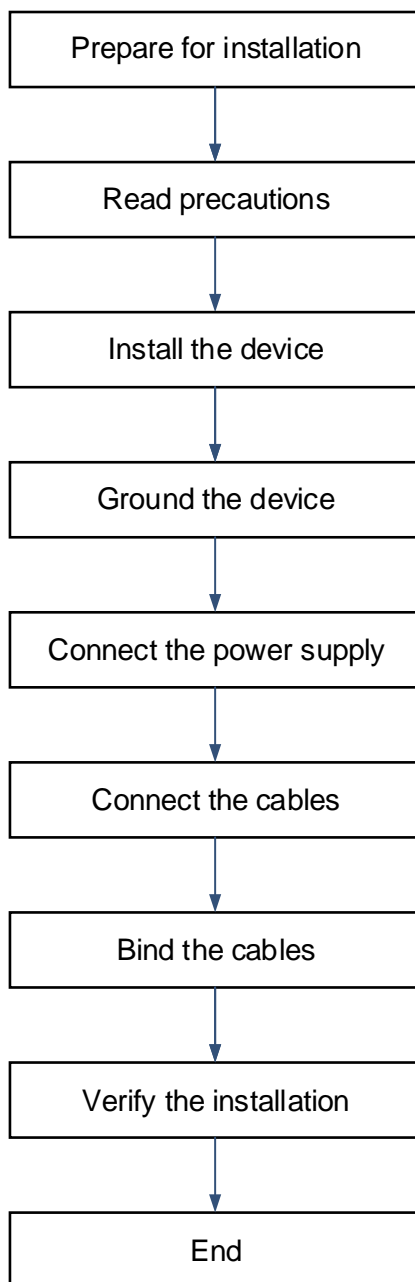

3.2 Before You Begin

Carefully plan and arrange the installation position, networking mode, power supply, and cabling before installation. Confirm the following requirements before installation:

- The installation site provides sufficient space for heat dissipation.
- The installation site meets the temperature and humidity requirements of the equipment.
- The power supply and required current are available at the installation site.
- The Ethernet cables have been deployed at the installation site.
- The selected power supply modules meet the system power requirements.
- The position of the indoor emergency power switch is identified before installation. In the case of an accident, cut off the power supply immediately.

3.3 Precautions

During installation, pay attention to the following:

- Do not power on the equipment during installation.
- Install the equipment in a well-ventilated position.
- Do not subject the equipment to high temperatures.
- Keep the equipment away from high voltage cables.
- Install the equipment indoors.
- Do not expose the equipment to a thunderstorm or strong electric field.
- Keep the equipment clean and dust-free.
- Cut off the power switch before cleaning the equipment.
- Do not wipe the equipment with a damp cloth.
- Do not wash the equipment with liquid.
- Do not open the enclosure when the equipment is working.
- Fasten the equipment tightly.
- Before powering off the equipment that contains a hard disk drive, be sure to switch off the power switch on the back panel of the router.

3.4 Installing a Router

Note

The RG-EG406XS supports both rack and workbench installation, while the RG-EG406XS-P supports workbench installation only.

3.4.1 Mounting the Router into a Rack

1. Precautions

If you want to install the RG-EG406XS router into a rack, mount the rack first. When mounting the rack, note the following:

- All expansion bolts for fastening the rack base to the ground should be installed and tightened in sequence from bottom to up (large flat washer, spring washer, and nut), and the installation holes on the base and the expansion bolts are properly aligned.
- The installed rack should not be moved.
- The installed rack should be vertical to the ground.
- When multiple racks are placed side by side in the equipment room, they should be aligned with each other, leaving an error of less than 5 mm (0.20 in.).
- The front/rear doors of the rack should be installed to allow you to open and close them smoothly. The locks should work normally, and all keys should be complete.
- There should be no unnecessary and informal labels inside the rack and on service modules.
- Filler panels are installed on vacant slots.
- The screws in the rack should be fastened tightly and be of the same model.
- The equipment is securely installed, and the screws on the panel should be fastened tightly.
- All wiring outlets at the top and bottom of the rack should be installed with rodent-resistant nets with clearance of no more than 15 mm (0.59 in.) in diameter to prevent rodents and other small animals from entering the rack.
- Antistatic wrist straps should be provided in the rack.

2. Installation Preparations

- (1) Plan the available space before installing the rack. Reserve enough space for the front and rear doors for equipment maintenance.
- (2) Install and fasten the rack in the designed position as planned.
- (3) Install the appropriate cable troughs and cables.
- (4) Install the tray and cable management brackets on the rack according to the number of equipment installed into the rack.

3. Installation Procedure

The RG-EG406XS router can be installed in a 19-inch EIA rack. The installation steps are as follows:

- (1) Remove the M3 x 6 mm Phillips countersunk head screws packaged with the rack-mount brackets, align one end of the rack-mount bracket against the side of the device, and securely fasten the rack-mount bracket using four M3 x 6 mm Phillips countersunk head screws. Follow the same procedure to install the other rack-mount bracket.

Figure 3-1 Securing the Rack-Mount Brackets

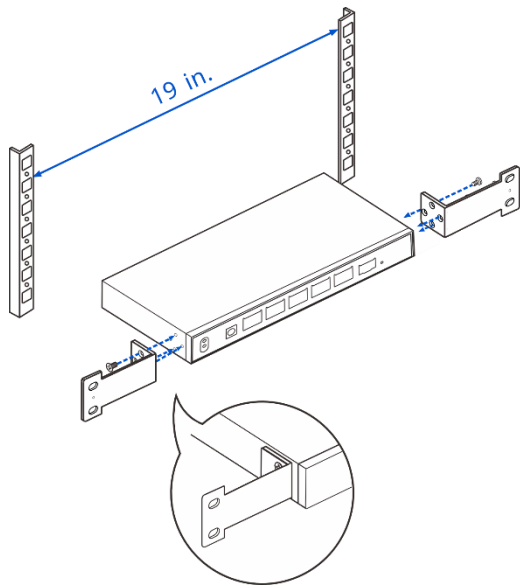
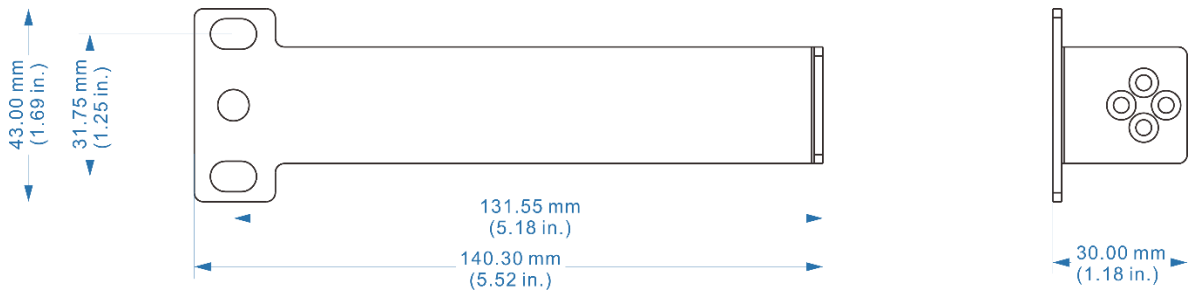
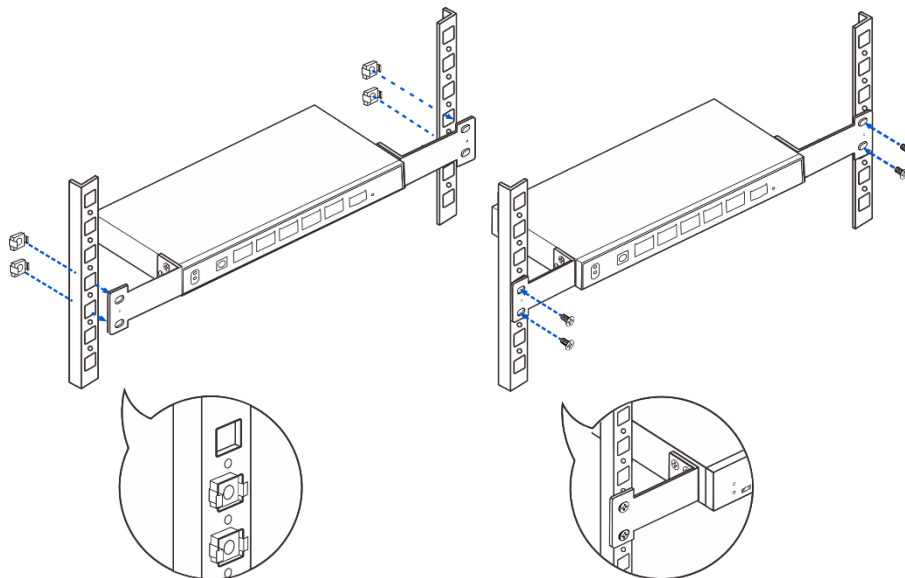

Table 3-2 Rack-Mount Bracket Dimensions



- (2) Mount the device into the rack and secure the other ends of the brackets to square-hole rack posts using the cage nuts and M6 screws.



3.4.2 Mounting the Router on a Workbench

If a standard 19-inch rack is unavailable, you can mount the router on a workbench.

- (1) Attach the four rubber pads to the four corners on the bottom of the device.

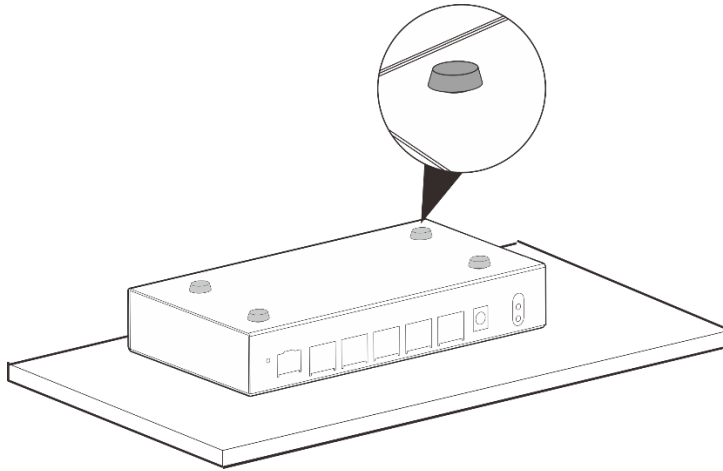

- (2) Place the device on the workbench to ensure adequate airflow and good heat dissipation.

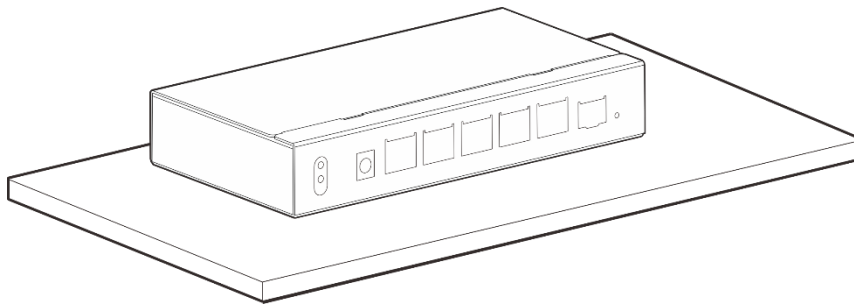

⚠ Caution

The workbench used for installing and operating the device must not be moved.

3.5 Connecting the Grounding Wire

The router has a grounding stud for grounding protection. Connect the grounding stud of the device to the grounding lug of the rack with a grounding wire. Then connect the grounding lug to the grounding bar in the equipment room.

Precautions:

- The cross-sectional area of the grounding wire should be determined according to the possible maximum current. Cables with good conductors should be used.
- Do not use bare wires.
- The resistance between the chassis and ground should be less than 1 ohm.

⚠ Caution

The cross-sectional area of the grounding wire should be at least 2.5 mm² (12 AWG).

3.6 Connecting the Power Cord

The device is equipped with a three-core power cord. You are advised to use a single-phase three-core power socket or a multi-function power socket with a neutral point connector. The neutral point of the power supply must be well grounded in the building. Typically the neutral point has been buried in the ground during the cabling. You need to confirm whether the power supply of the building has been properly grounded.

Please connect the power cord based on the following steps:

- (1) Insert the ring of the adapter's DC connector into the DC input plug of the device. Plug the end of the power cord into the power socket on the adapter and the other end into the AC power socket. For those devices without the adapter power supply, plug the end of the power cord into the power socket on the rear panel of the device and the other end of the power cord into the AC power socket.
- (2) Please check the status of the system LED on the front panel of the device. If the LED is on, it means that the power cord is connected correctly. Otherwise, please check the power cord connection.

Caution

- Please use the power supply adapter and power cord delivered with the equipment to prevent any potential accidents.
 - Verify that the AC socket is reliably connected to the protective grounding system of the building. If not, a protective grounding wire should be used to connect the protective grounding lug of the AC socket to the protective grounding system of the building.
 - During the installation, the ground connection must always be made first and disconnected last.
 - The power socket should be installed in an easily operable position near the equipment.
-

3.7 Connecting Cables

- Connect one end of the Ethernet cable to the Ethernet port of the device, and the other end to the NMS or a control client.
- Insert the twisted pair cable with an RJ45 connector into the corresponding port as indicated on the panel, and distinguish the crossover cable and the straight-through cable.

3.8 Bundling Cables

3.8.1 Precautions

- Bundle cables in an esthetically pleasing way.
- Ensure that the twisted pairs have natural bends or bends of large radius at the connectors.
- Do not overtighten the cable bundle as it may reduce the cable life and performance.

3.8.2 Bundling Steps

- (1) Bundle the hanging part of the twisted pairs using cable ties and lead them to both sides of the equipment for convenience.
- (2) Fasten the twisted pairs to the cable trough of the mounting bracket.
- (3) Extend the twisted pairs under the equipment and route them in a straight line.

3.9 Verifying Installation

3.9.1 Verifying the Equipment

- Verify if the external power supply matches with the distribution panel of the rack.
- Verify if the front/back rack doors can be closed after the equipment is installed.
- Verify that the rack and all cables are securely fastened.
- Verify that the equipment has been installed in the rack.

3.9.2 Verifying Cable Connection

- Verify that the cable matches the port type.
- Verify that cables are properly bundled.

3.9.3 Verifying Power Supply

- Verify that the power cord is properly connected and compliant with safety requirements.
- Verify that the equipment is operational after power-on.

4 Verifying Operating Status

4.1 Setting up Configuration Environment

- **Wired Connection:** Connect the LAN port of the router to the Ethernet port of a PC with an Ethernet cable. Configure the PC to get an IP address automatically.
- **Wireless Connection:** Connect the AP to the LAN port of the router with an Ethernet cable. The AP will automatically broadcast SSID "@Ruijie-mXXXX" (XXXX are the last four characters of the MAC address on the device label.) after power-on. Perform configuration on the device after the PC is connected to the wireless network.

Figure 4-1 Configuration Environment

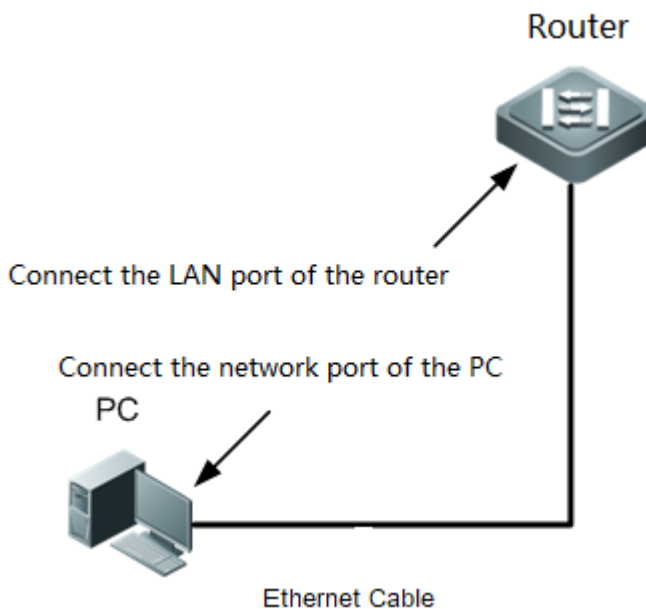

4.2 Checklist

4.2.1 Checklist before Power-on

- The equipment is properly grounded.
- The power cord is properly connected.
- The input voltage meets the requirement.
- The Ethernet cable is properly connected, the client such as a PC used for configuration is already turned on, and the parameters are configured correctly.

4.2.2 Checklist after Power-on

After the equipment is powered on, check whether the LEDs on it are normal to ensure the proper configuration.

4.3 Log In to the Web Interface

- (1) Start up the PC and configure the local connection attribute on the PC. Set the static IP address of the PC to 192.168.110.XXX (2–254).

Figure 4-2 Modifying the PC's IP Address

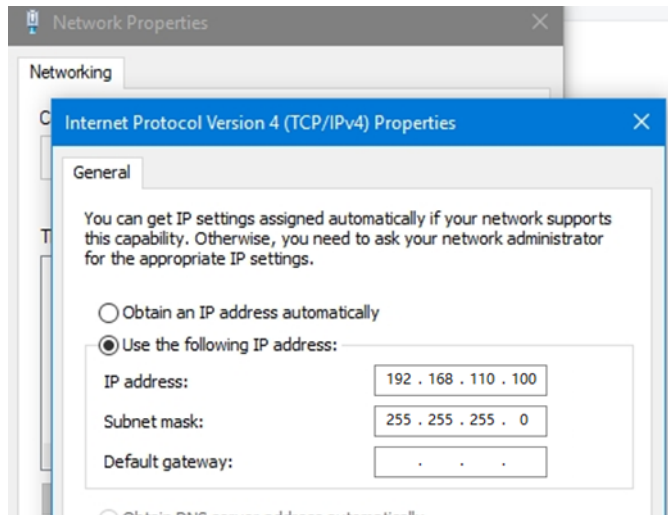

- (2) Open a browser, enter 192.168.110.1 into the address bar of the browser, and press **Enter**.

⚠ Caution

Use the default password "admin" to log in to the switch for the first time. To ensure security, you are advised to change the password after login, and update the password regularly.

5 Troubleshooting

5.1 General Troubleshooting Procedure

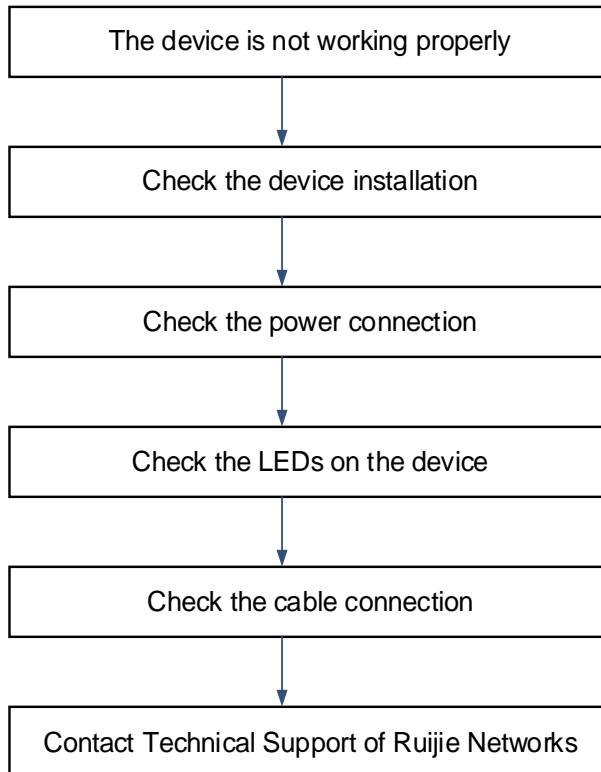

5.2 Common Troubleshooting Procedures

5.2.1 Password Loss

Press the **Reset** button for more than 5 seconds to restore the device to factory settings and reset the system login password.

5.2.2 System LED Error

Cut off all power supplies first. Check if the cables of the rack have been correctly connected and the power socket is functional. Check whether the power cord is tightly connected to the rack power socket. Check whether the power cord is tightly connected and the adapter's DC connector works properly.

6 Appendix

6.1 Connectors and Media

6.1.1 10/100/1000/2500BASE-T Port

The 10/100/1000/2500BASE-T port supports auto-negotiation for 10 Mbps, 100 Mbps, 1 Gbps, and 2.5 Gbps connections and also supports auto MDI/MDIX Crossover.

Compliant with IEEE 802.3bz, 2500BASE-T requires Category 5e 100-ohm UTP or STP (STP is recommended) with a maximum distance of 100 meters (328 feet). 2500BASE-T requires all four pairs of wires to be connected for data transmission, as shown in [Figure 6-1](#).

Compliant with IEEE 802.3ab, 1000BASE-T requires Category 5e 100-ohm UTP or STP (STP is recommended) with a maximum distance of 100 meters (328 feet). 1000BASE-T requires all four pairs of wires to be connected for data transmission, as shown in [Figure 6-1](#).

Figure 6-1 2500BASE-T/1000BASE-T Connection

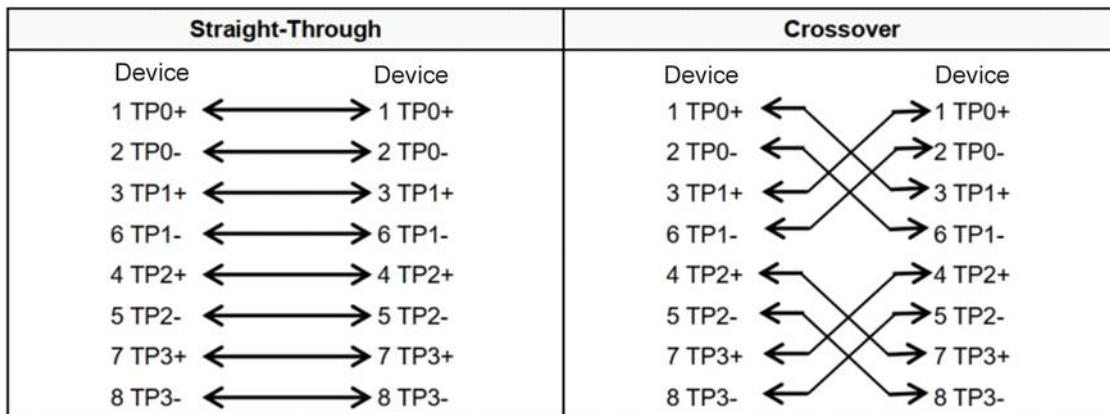

The 10/100BASE-T port can also be connected by cables of the preceding specifications. Besides, the 10BASE-T port can be connected by 100-ohm Category 3, Category 4, and Category 5 cables with a maximum distance of 100 meters (328.08 feet). The 100BASE-TX port can be connected by 100-ohm Category 5 cables with a maximum distance of 100 meters (328.08 feet). The following table lists pin assignments for the 10/100BASE-T port.

Table 6-1 100BASE-TX/10BASE-T Pin Assignments

Pin	Socket	Plug
1	Input Receive Data+	Output Transmit Data+
2	Input Receive Data-	Output Transmit Data-
3	Output Transmit Data+	Input Receive Data+
6	Output Transmit Data-	Input Receive Data-

Pin	Socket	Plug
4,5,7,8	Not Used	Not Used

Figure 6-2 shows wiring of straight-through and crossover cables for a 100BASE-TX/10BASE-T port.

Figure 6-2 100BASE-TX/10BASE-T Connection

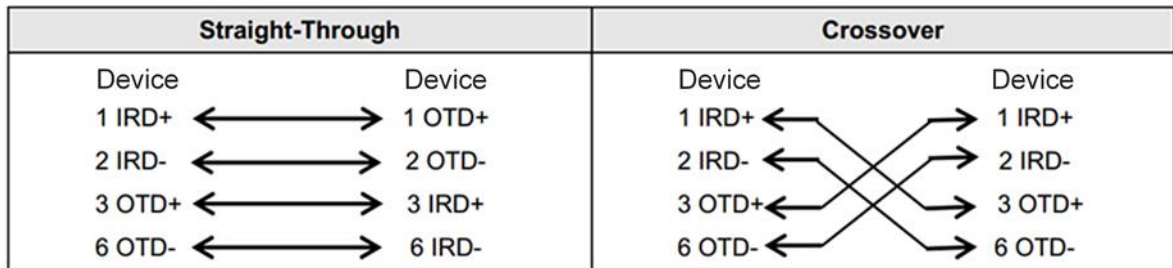

- Optical Cable Connection

For the optical ports, select single-mode or multimode optical cables for connections according to the optical transceiver connected. Figure 6-3 shows the connection schematic diagram.

Figure 6-3 Optical Cable Connections

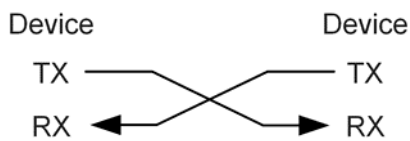

6.2 Mini-GBIC and 10GE SFP+ Module Specifications

SFP modules (mini-GBIC module) and 10GE SFP+ modules are available to cope with port types of switch modules. You can select the mini-GBIC module to suit your specific needs. The models and technical specifications of some mini-GBIC and 10GE SFP+ modules are listed below. For details, see *Ruijie module Installation and Reference Guide*.

Table 6-2 Models and Specifications of the 1GE Mini-GBIC (SFP) Modules

Model	Wave Length (nm)	Fiber Type	DDM (Yes/No)	Intensity of Transmitted Light (dBm)		Intensity of Received Light (dBm)	
				Min	Max	Min	Max
MINI-GBIC-SX-MM850	850	MMF	No	-9.5	-3	-17	0
MINI-GBIC-LX-SM1310	1310	SMF	No	-9.5	-3	-20	-3

Model	Wave Length (nm)	Fiber Type	DDM (Yes/No)	Intensity of Transmitted Light (dBm)		Intensity of Received Light (dBm)	
				Min	Max	Min	Max
MINI-GBIC-LH40-SM1310	1310	SMF	Yes	-2	3	-22	-3
GE-SFP-LX20-SM1310-BIDI	1310TX/1550 RX	SMF	Yes	-9	-3	-20	-3
GE-SFP-LX20-SM1550-BIDI	1550TX/1310 RX	SMF	Yes	-9	-3	-20	-3
GE-SFP-LH40-SM1310-BIDI	1310TX/1550 RX	SMF	Yes	-5	0	-24	-1
GE-SFP-LH40-SM1550-BIDI	1550TX/1310 RX	SMF	Yes	-5	0	-24	-1
MINI-GBIC-ZX80-SM1550	1550	SMF	Yes	0	4.7	-22	-3
MINI-GBIC-ZX100-SM1550	1550	SMF	Yes	0	5	-30	-9
SFP-MM850	850	MMF	No	-9.5	-3	-17	0
SFP-SM1310	1310	SMF	No	-9.5	-3	-20	-3
GE-SFP-ZX	850	MMF	Yes	-9.5	-3	-17	0
GE-SX-MM850	850	MMF	Yes	-9.5	-3	-17	0
GE-LX-SM1310	1310	SMF	Yes	-9	-3	-20	-3
SFP-S4-R1000P1 v1	1310	SMF	Yes	0	5	-30	-9

Table 6-3 Models of 1GE SFP Copper Module

Standard	Model	DDM (Yes/No)
1000BASE-T	Mini-GBIC-GT	No

Table 6-4 SFP Module Cabling Specification

SFP Model	Interface Type	Fiber Type	Core Size(μm)	Cabling Distance
MINI-GBIC-SX-MM850	LC	MMF	62.5/125	275 m (902.23 ft.)
			50/125	550 m (1804.46 ft.)
MINI-GBIC-LX-SM1310	LC	SMF	9/125	10 km (6.21 miles)
MINI-GBIC-LH40-SM1310	LC	SMF	9/125	40 km (24.85 miles)
GE-SFP-SX-SM1310-BIDI	LC	MMF	50/125	500 m (1640.42 ft.)
GE-SFP-SX-SM1550-BIDI	LC	MMF	50/125	500 m (1640.42 ft.)
GE-SFP-LX20-SM1310-BIDI	LC	SMF	9/125	20 km (12.43 miles)
GE-SFP-LX20-SM1550-BIDI	LC	SMF	9/125	20 km (12.43 miles)
GE-SFP-LH40-SM1310-BIDI	LC	SMF	9/125	40 km (24.85 miles)
GE-SFP-LH40-SM1550-BIDI	LC	SMF	9/125	40 km (24.85 miles)
MINI-GBIC-ZX80-SM1550	LC	SMF	9/125	80 km (49.71 miles)
MINI-GBIC-ZX100-SM1550	LC	SMF	9/125	100 km (62.14 miles)
SFP-MM850	LC	MMF	50/125	500 m (1640.42 ft.)
SFP-SM1310	LC	SMF	9/125	10 km (6.21 miles)
GE-SFP-ZX	LC	MMF	50/125	550 m (1804.46 ft.)
GE-SX-MM850	LC	MMF	50/125	500 m (1640.42 ft.)
GE-LX-SM1310	LC	SMF	9/125	10 km (6.21 miles)
SFP-S4-R1000P1 v1	LC	SMF	9/125	10 km (6.21 miles)
Mini-GBIC-GT	RJ45	Category 5 (or above) UTP or STP		100 m (328.08 ft.)
GE-SFP-GT	RJ45	Category 5 (or above) UTP or STP		100 m (328.08 ft.)

SFP Model	Interface Type	Fiber Type	Core Size(μm)	Cabling Distance
SFP-GT	RJ45	Category 5 (or above) UTP or STP		100 m (328.08 ft.)

Note

- For the optical transceiver with a transmission distance exceeding 40 km (24.85 miles) or above, add one in-line optical attenuator on the link to avoid the overload of the optical receiver when short single-mode fiber-optic cables are used.
- Optical transceivers generate laser. Do not look directly into the optical transceiver.
- To keep optical transceivers clean, use dust caps when the transceivers are not connected to optical cables.
- No extra cables are needed when SFP cables are used. To allow two ports to communicate easily, install the two ends of an SFP cable into corresponding ports.

Table 6-5 Specifications of SFP BIDI Optical Transceiver Pairs

Rate/Distance	Module Pairs
1000 Mbps/500 m (1640.42 ft.)	GE-SFP-SX-SM1310-BIDI GE-SFP-SX-SM1550-BIDI
1000 Mbps/20 km (12.43 miles)	GE-SFP-LX20-SM1310-BIDI GE-SFP-LX20-SM1550-BIDI
1000 Mbps/40 km (24.85 miles)	GE-SFP-LH40-SM1310-BIDI GE-SFP-LH40-SM1550-BIDI
10GE/10 km (6.21 miles)	XG-SFP-LR-SM1270-BIDI XG-SFP-LR-SM1330-BIDI

Caution

The BIDI modules must be used in pairs, for example, FE-SFP-LX20-SM1310-BIDI and FE-SFP-LX20-SM1550-BIDI are used together.

Table 6-6 Models and Specifications of 10GE SFP+ Modules

Model	Wavelength (nm)	DDM (Yes/No)	Fiber Type	Transmit (dBm)		Receive (dBm)	
				MIN	MAX	MIN	MAX
XG-SFP-SR-MM850	850	Yes	MMF	-7.3	-1	-9.9	-1

Model	Wavelength (nm)	DDM (Yes/No)	Fiber Type	Transmit (dBm)		Receive (dBm)	
				MIN	MAX	MIN	MAX
XG-SR-MM850	850	Yes	MMF	-7.3	-1	-9.9	-1
SFP+MM850	850	Yes	MMF	-7.3	-1	-9.9	-1
XG-SFP-LR-SM1270-BIDI	1270	No	SMF	-6.5	0.5	-14.4	0.5
XG-SFP-LR-SM1330-BIDI	1330	No	SMF	-6.5	0.5	-14.4	0.5
XG-LR-SM1310	1310	Yes	SMF	-8.2	0.5	-14.4	0.5
SFP+SM1310	1310	Yes	SMF	-8.2	0.5	-14.4	0.5
XG-SFP-LR-SM1310	1310	Yes	SMF	-8.2	0.5	-14.4	0.5
XG-eSFP-LR-SM1310	1310	Yes	SMF	-8.2	0.5	-14.4	0.5
XG-SFP-ER-SM1550	1550	Yes	SMF	-4.7	4	-11.3	-1
XG-SFP-ZR-SM1550	1550	Yes	SMF	0	4	-24	-7
SFP-S4-R1000P1 v2	1310	Yes	SMF	-8.2	0.5	-14.4	0.5
SFP-S1-R1000P1	1310	Yes	SMF	-8.2	0.5	-14.4	0.5
SFP+1310	1310	Yes	SMF	-8.2	0.5	-14.4	0.5
SFP-M3-R1000P1	850	Yes	MMF	-7.3	-1	-11.1	-1
XG-LR-SM1310	1310	Yes	SMF	-8.2	0.5	-14.4	0.5
HSFP-XG-SFP-LR-SM1310	1310	Yes	SMF	-8.2	0.5	-14.4	0.5
XG-SFP-SR-MM850-I	850	Yes	MMF	-7.3	-1	-9.9	-1

Model	Wavelength (nm)	DDM (Yes/No)	Fiber Type	Transmit (dBm)		Receive (dBm)	
				MIN	MAX	MIN	MAX
XG-SFP-LR-SM1310-I	1310	Yes	SMF	-8.2	0.5	-14.4	0.5

Table 6-7 Models and Specifications of 10GE SFP+ AOC Modules

Model	Module Type	Connector	Length (m)	Conductor Diameter(AWG)	Data Rate (Gbps)	Support DDM (Yes/No)
XG-SFP-AOC1M	Active	SFP+	1	\	10.3125	Yes
XG-SFP-AOC3M	Active	SFP+	3	\	10.3125	Yes
XG-SFP-AOC5M	Active	SFP+	5	\	10.3125	Yes
XG-SFP-AOC10M	Active	SFP+	10	\	10.3125	Yes

Note

- SFP+ module types are subject to change without prior notice. For more accurate information about the optical transceivers, contact the Ruijie marketing or technical support personnel.
- The DDM function of the AOC cable does not report transmit power, and the transmit power may be displayed as N/A.

Table 6-8 10GE SFP+ Module Cabling Specification

Model	Port Type	Fiber Type	Core Size (μm)	Modal Bandwidth (MHz.km)	Cabling Distance
XG-SFP-SR-MM850	LC	MMF	50/125	2000(OM3)	300 m (984.25 ft.)
XG-SR-MM850	LC	MMF	50/125	2000(OM3)	300 m (984.25 ft.)

Model	Port Type	Fiber Type	Core Size (µm)	Modal Bandwidth (MHz.km)	Cabling Distance
SFP+MM850	LC	MMF	50/125	2000(OM3)	300 m (984.25 ft.)
XG-SFP-LR-SM1270-BIDI	LC	SMF	9/125	N/A	10 km (6.21 miles)
XG-SFP-LR-SM1330-BIDI	LC	SMF	9/125	N/A	10 km (6.21 miles)
XG-SFP-LR-SM1310	LC	SMF	9/125	N/A	10 km (6.21 miles)
SFP+SM1310	LC	SMF	9/125	N/A	10 km (6.21 miles)
XG-SFP-ER-SM1550	LC	SMF	9/125	N/A	40 km (24.85 miles)
XG-SFP-ZR-SM1550	LC	SMF	9/125	N/A	80 km (49.71 miles)
SFP-S4-R1000P1 v2	LC	SMF	9/125	N/A	10 km (6.21 miles)
SFP-S1-R1000P1	LC	SMF	9/125	N/A	10 km (6.21 miles)
SFP+1310	LC	SMF	9/125	N/A	10 km (6.21 miles)
SFP-M3-R1000P1	LC	MMF	50/125	2000(OM3)	300 m (984.25 ft.)

Model	Port Type	Fiber Type	Core Size (μm)	Modal Bandwidth (MHz.km)	Cabling Distance
XG-LR-SM1310	LC	SMF	9/125	N/A	10 km (6.21 miles)
HSFP-XG-SFP-LR-SM1310	LC	SMF	9/125	N/A	10 km (6.21 miles)
XG-SFP-SR-MM850-I	LC	MMF	50/125	2000(OM3)	300 m (984.25 ft.)
XG-SFP-LR-SM1310-I	LC	SMF	9/125	N/A	10 km (6.21 miles)

6.3 Cabling Recommendations

When the RG-EG406XS is installed in a standard 19-inch rack, cables are routed upward or downward along the sides of the cable management bracket according to the actual situation in the equipment room. All adapted connectors should be placed at the bottom of the rack in an orderly manner instead of outside the rack that is easy to touch. Power cords are routed beside the rack. Top cabling or bottom cabling is adopted according to the actual situation in the equipment room, such as the positions of the DC power distribution box, AC socket, or lightning protection box.

Requirements for the Minimum Cable Bending Radius

- The bend radius of a fixed power cord, Ethernet cable, or flat cable should be over five times greater than their respective external diameters. The bend radius of these cables that are often bent or plugged should be over seven times greater than their respective external diameters.
- The bend radius of a fixed common coaxial cable should be over seven times greater than its external diameter. The bend radius of these cables that are often bent or plugged should be over 10 times greater than their respective external diameters.
- The minimum bend radius of a high-speed cable, such as an SFP+ cable, should be over five times greater than its external diameter. The bend radius of these cables that are often bent or plugged should be over 10 times greater than their respective external diameters.

Requirement for the Minimum Bend Radius of Optical Cables

- The diameter of the optical cable tray should be over 25 times greater than that of the optical cable.
- When an optical cable is moved, the bend radius of the optical cable should be over 20 times greater than the diameter of the optical cable.
- During cabling of an optical cable, its bend radius should be over 10 times greater than its diameter.

Precautions for Cable Binding

- Before cables are bundled, mark labels and stick the labels to cables wherever appropriate.
- Cables should be neatly and properly bundled in the rack without twisting or bending, as shown in [Figure 6-4](#).

Figure 6-4 Bundling Cables (1)

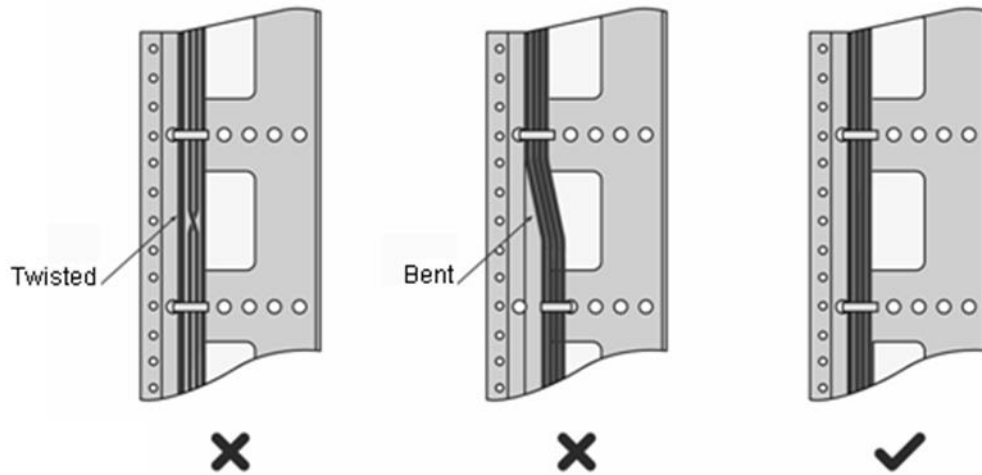

- Cables of different types (such as power cords, signal cables, and grounding wires) should be separated into cabling and bundling. Mixed bundling is disallowed. When they are close to each other, you are advised to adopt crossover cabling. In the case of parallel cabling, maintain a minimum distance of 30 mm (1.18 in.) between power cords and signal cables.
- The cable management brackets and cabling troughs inside and outside the rack should be smooth without sharp corners.
- The metal holes traversed by cables should have a smooth and fully rounded surface or an insulated lining.
- Use cable ties to bundle up cables properly. Please do not connect two or more cable ties to bundle up cables.
- After bundling up cables with cable ties, cut off the remaining part. The cut should be smooth and trim without sharp corners, as shown in [Figure 6-5](#).

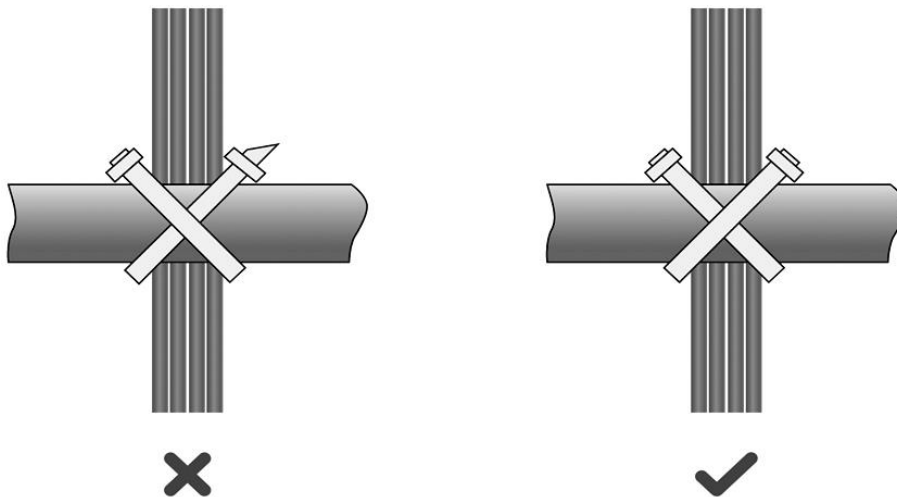
Figure 6-5 Bundling Cables (2)

- When cables need to be bent, bundle them first but do not tie cables within the bend. Otherwise, stress may be generated on the cables and cause the wires inside to break, as shown in [Figure 6-6](#).

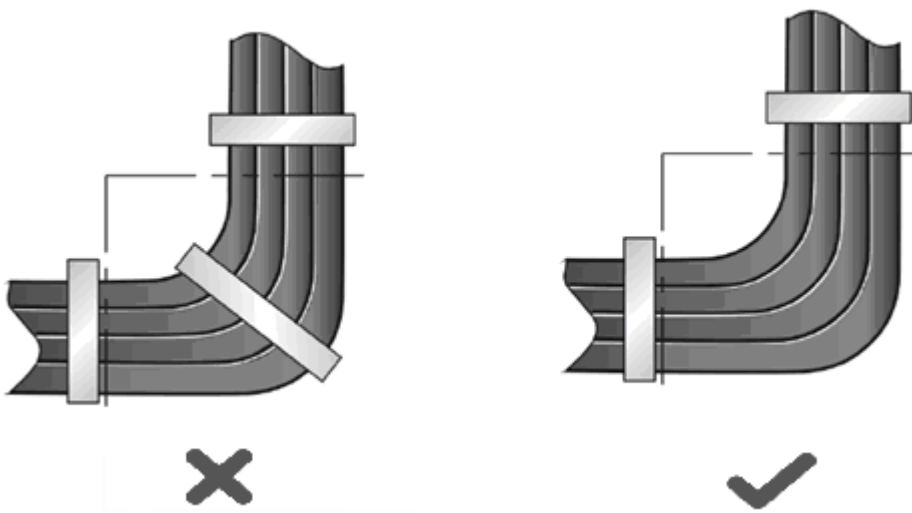
Figure 6-6 Bundling Cables (3)

- Cables not to be assembled or the remaining parts of cables should be folded and placed in a proper position of the rack or cable trough. The proper position refers to a position that does not affect the equipment running or damage the equipment or cables.
- Do not bind power cords to the guide rails of moving parts.
- The power cords connecting moving parts such as door grounding wires should be reserved with some excess after being assembled. This can avoid tension or stress on power cords. After the moving part is installed, the remaining cable part should not touch heat sources, sharp corners, or sharp edges. If heat sources must be touched, high-temperature cables should be used.
- When using screw threads to secure a cable lug, ensure that the bolt or screw is properly tightened and take measures to prevent it from loosening, as shown in [Figure 6-7](#).

Figure 6-7 Cable Fastening

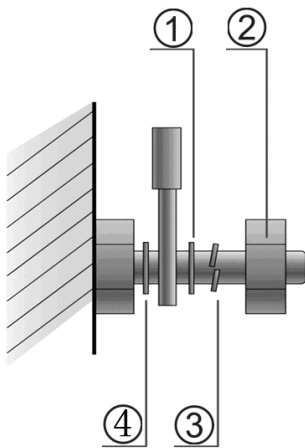

- | | |
|----------------|------------------|
| 1. Flat washer | 3. Spring washer |
| 2. Nut | 4. Flat washer |

- Hard power cords should be fastened in the terminal connection area to prevent stress on the terminal connection and cable.
- Do not use tapping screws to secure cable lugs.
- Power cords of the same type and in the same cabling direction should be bundled up into cable bunches, with cables in cable bunches clean and straight.
- Bundle up cables by using cable tie according to [Table 6-9](#).

Table 6-9 Cable Bunch

Cable Bunch Diameter	Binding Space
10 mm (0.39 in.)	80–150 mm (3.15–5.91 in.)
10–30 mm (0.39–1.18 in.)	150–200 (5.91–7.87 in.)
30 mm (1.18 in.)	200–300 (7.87–11.81 in.)

- Do not tie cables or bundles in a knot.
- For wiring terminal blocks (such as circuit breakers) with cord end terminals, the metal part of the cord end terminal should not be exposed outside the terminal block during assembly.