

Ruijie Reyee RG-ES210GS-P Switch

Installation Guide



Copyright

Copyright © 2025 Ruijie Networks

All rights are reserved in this document and this statement.

Without the prior written consent of Ruijie Networks, no organization or individual is permitted to reproduce, extract, back up, modify, or distribute the content of this document in any manner or form. It is also prohibited to translate the document into other languages or use any or all parts of it for commercial purposes.

 and other Ruijie networks logos are trademarks of Ruijie Networks.

All other trademarks or registered trademarks mentioned in this document are owned by their respective owners.

Disclaimer

The products, services, or features you purchase are subject to commercial contracts and terms, and some or all of the products, services, or features described in this document may not be available for you to purchase or use. Except for the agreement in the contract, Ruijie Networks makes no explicit or implicit statements or warranties with respect to the content of this document.

The names, links, descriptions, screenshots, and any other information regarding third-party software mentioned in this document are provided for your reference only. Ruijie Networks does not explicitly or implicitly endorse or recommend the use of any third-party software and does not make any assurances or guarantees concerning the applicability, security, or legality of such software. You should choose and use third-party software based on your business requirements and obtain proper authorization. Ruijie Networks assumes no liability for any risks or damages arising from your use of third-party software.

The content of this document will be updated from time to time due to product version upgrades or other reasons, Ruijie Networks reserves the right to modify the content of the document without any notice or prompt.

This manual is designed merely as a user guide. Ruijie Networks has tried its best to ensure the accuracy and reliability of the content when compiling this manual, but it does not guarantee that the content of the manual is completely free of errors or omissions, and all the information in this manual does not constitute any explicit or implicit warranties.

Preface

Intended Audience

This document is intended for:

- Network engineers
- Technical support and servicing engineers
- Network administrators

Technical Support

- Ruijie Reye website: <https://reyee.ruijie.com>
- Online support center: <https://reyee.ruijie.com/en-global/support>
- Case portal: <https://www.ruijie.com/support/caseportal>
- Community: <https://community.ruijie.com>
- Email support: service_rj@ruijie.com
- Live chat: <https://reyee.ruijie.com/en-global/rita>

Conventions

1. Signs

This document also uses signs to indicate some important points during the operation. The meanings of these signs are as follows:

Danger

An alert that calls attention to safety instruction that if not understood or followed can result in personal injury.

Warning

An alert that calls attention to important rules and information that if not understood or followed can result in data loss or equipment damage.

Caution

An alert that calls attention to essential information that if not understood or followed can result in function failure or performance degradation.

Note

An alert that contains additional or supplementary information that if not understood or followed will not lead to serious consequences.

Specification

An alert that contains a description of product or version support.

2. Note

This manual provides installation steps, troubleshooting, technical specifications, and usage guidelines for cables and connectors. It is intended for users who want to understand the above and have extensive experience in network deployment and management, and assume that users are familiar with related terms and concepts.

Contents

Preface	I
1 Product Overview	1
1.1 Package Contents.....	1
1.2 Technical Specifications	1
1.3 Product Appearance	4
1.3.1 Front Panel.....	4
1.3.2 Rear Panel	5
1.4 Cooling.....	5
2 Preparing for Installation	7
2.1 Safety Precautions.....	7
2.1.1 Installation Safety.....	7
2.1.2 Handling Safety.....	7
2.1.3 Electric Safety	7
2.1.4 Electrostatic Discharge Safety.....	8
2.1.5 Laser Safety	8
2.2 Installation Environment Requirements.....	9
2.2.1 Ventilation and Cooling Requirements	9
2.2.2 Temperature and Humidity Requirements	9
2.2.3 Cleanliness.....	9
2.2.4 Anti-interference	10
2.2.5 Grounding Requirements.....	10
2.2.6 Lightning Protection Requirements	11
2.2.7 EMI Requirements	12

2.3 Tools	12
3 Installing the Switch	13
3.1 Installation Procedure	13
3.2 Before You Begin.....	13
3.3 Installing the Switch	13
3.3.1 Mounting the Switch on the Wall	14
3.3.2 Installing the Switch on a Workbench.....	15
3.4 Verifying Installation.....	15
4 Debugging	17
4.1 Powering On the Equipment.....	17
4.2 Logging In to the Management Interface.....	17
5 Common Troubleshooting	18
5.1 Troubleshooting Flowchart	18
5.2 Common Troubleshooting	18
Appendix A — Connectors and Media	20
Appendix B — Mini-GBIC and SFP Modules.....	22
Appendix C — Lightning Protection	25
Appendix D — Cabling Recommendations	28
Appendix E — Machine Room Site Selection.....	32

1 Product Overview

Model	10/100Base-T Ports with Auto-Negotiation	10/100/1000Base-T Ports with Auto-Negotiation	1000Base-X SFP Port	Console Port
RG-ES210GS-P	/	10 (Ports 1-8 support PoE/PoE+)	10F Port supports SFP	/

Note

- A SFP port is not downward compatible with 100Base-FX.
- 1000Base-T ports are downward compatible with 100Base-TX and 10Base-T ports.

1.1 Package Contents

Table 1-1 RG-ES210GS-P Package Contents

Item	Quantity
Switch	1
Power adapter	1
User Manual	1
Power cord	1
Warranty card	1

Note

The package contents above are intended to provide a general overview, and are subject to the terms of the order contract. Please check your goods carefully against the package contents or order contract. If you have any questions, please contact the distributor.

1.2 Technical Specifications

Table 1-2 Technical Specifications

System Specifications	Flash memory	4 MB
	Forwarding rate	14.8 Mpps
	Switching capacity	20 Gbps(bit/s)

Port Specifications	Total number of RJ45 ports	10
	Total number of optical ports	1
	Number of 1GE combo ports	1
	Number of 1GE SFP ports	1
	Number of 10/100/1000BASE-T ports	10
	Reset button	1
	DIP switch	<ul style="list-style-type: none"> ● LED mode switch toggled to left (Mode 1): The port LED status indicates the status of traffic transmission. Solid green means that the port is link up, while blinking green means that the port is transmitting and receiving data. ● LED mode switch toggled to right (Mode 2): The port LED status indicates the PoE status. Solid green means that the port is supplying power, while blinking green means that the port is in power overload state.
Power Supply and Consumption	PoE Out standard	PoE/PoE+ (IEEE 802.3af/at)
	Number of PoE/PoE+ Out ports	8
	PoE budget per port	30 W
	PoE budget	120 W
	PoE power pins	1–2 (+), 3–6 (-)
	Power input	DC adapter: <ul style="list-style-type: none"> ● Rated input voltage: 100 V AC to 240 V AC, 50 Hz to 60 Hz ● Maximum input voltage: 90 V AC to 264 V AC, 47 Hz to 63 Hz ● Rated input current: 2.5 A Output: <ul style="list-style-type: none"> ● Rated output voltage: 54 V DC ● Maximum output current: 2.4 A
	Maximum power consumption	<ul style="list-style-type: none"> ● 10 W (with no PoE load) ● 130 W (with PoE full load)
	Power supply	DC power adapter
Dimensions and Weight	Casing	Metal

	Product dimensions (W x D x H)	202 mm x 108 mm x 28 mm (7.95 in. x 4.25 in. x 1.10 in.)
	Weight	<ul style="list-style-type: none"> ● 0.55 kg (1.21 lbs) (without packaging materials) ● 1.65 kg (3.64 lbs) (with packaging materials)
Environment and Reliability	Fan	Fanless design
	Cooling	Natural cooling
	Mounting options	Wall/Desk
	Hot swapping of cables	Hot swapping supported by the service port and power connector
	MTBF	200,000 hours
	Operating temperature	0°C to 40°C (32°F to 104°F)
	Storage temperature	-40°C to +70°C (-40°F to +158°F)
	Operating humidity	10% RH to 90% RH (non-condensing)
	Storage humidity	5% RH to 95% RH (non-condensing)
	Altitude	-500 m to +5,000 m (-1,640.42 ft. to +16,404.20 ft.)
	ESD protection	<ul style="list-style-type: none"> ● Air discharge: 8 kV ● Contact discharge: 6 kV
	Surge protection	<ul style="list-style-type: none"> ● Service port: ±6 kV for common mode ● Power connector: ±4 kV for common mode and ±2 kV for differential mode
	Max. Ground Leakage Current	≤ 1.5 mA
Certification and Regulatory Compliance	EMC	EN 55032 EN 61000-3-2 EN 61000-3-3 EN 55035 EN 300 386
	Safety compliance	EN 62638-1
	Certification	CE, FCC
Interface	EEE	Yes

Warning

The power can not be repaired, do not disassemble it to avoid the risk of an electric shock.

Caution

Operation of this equipment in a residential environment could cause radio interference.

1.3 Product Appearance

The RG-ES210GS-P switch provides 10 × 10/100/1000Base-T ports (port 10 is a GE combo port.) on the front panel, and a DC power input port for 54V PoE injector on the back panel.

Figure 1-1 Appearance of RG-ES210GS-P

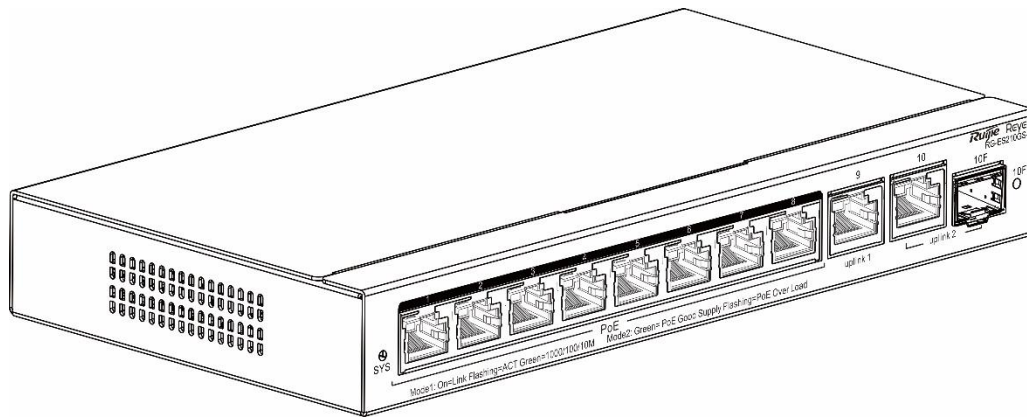

1.3.1 Front Panel

Figure 1-2 Front Panel of RG-ES210GS-P

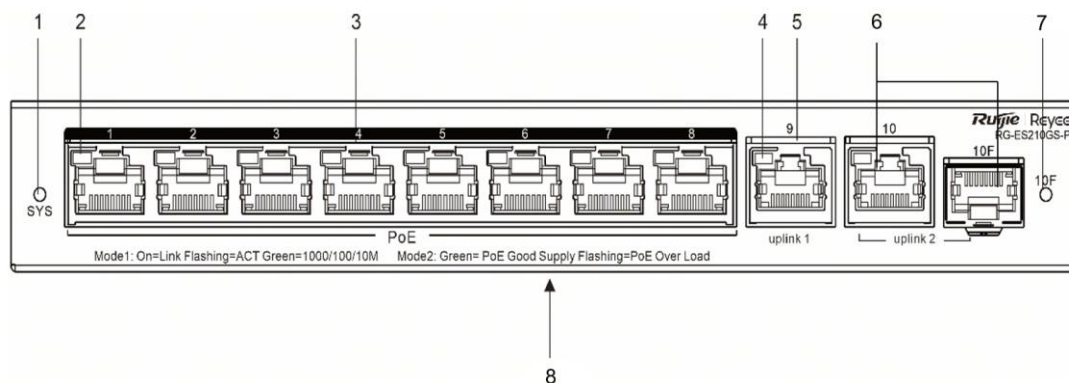

Note:	1. System status indicator of the switch	5. 10/100/1000Base-T port with auto-negotiation
	2. Electrical port status indicator	6. 1GE combo port
	3. 10/100/1000Base-T port with auto-negotiation	7. Optical port status indicator
	4. Electrical port status indicator	8. Label (at the bottom)

1.3.2 Rear Panel

Figure 1-3 Back Panel of RG-ES210GS-P

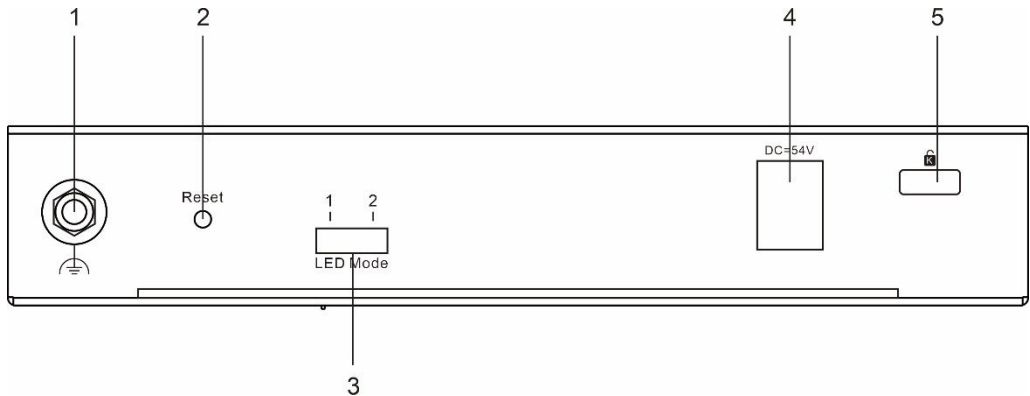

Note:	1. Grounding stud	4. DC input
	2. Reset button	5. Kensington lock
	3. Port LED switch	

Note

LED switch toggled to right (Mode 2): The port LED status indicates the PoE status. Solid green means that the port is supplying power, while blinking green means that the port is in power overload state.

1.4 Cooling

RG-ES210GS-P adopts natural cooling. To ensure that the switch works properly in the specified environment, a minimum clearance of 100 mm (3.94 in.) must be maintained around the device to ensure proper ventilation. Dust the device every three months to avoid blocking the ventilation openings on the housing.

Table 1-3 LED

LED	Panel Identification	status	Description
Status LED	SYS	Off	System is not powered on.
		Blinking green	If the power of PoE exceeds 120W, the newly connected PD cannot be powered up because of insufficient

LED	Panel Identification	status	Description
			power, but the switching function will remain affected.
		Solid green	System is operating normally.
PoE status indicator of the RJ-45 port	1-8	Off	PoE is disabled.
		Solid green	PoE is enabled.
		Blinking green	PoE is abnormal.
RJ-45 Port Link/Ack Status LED	1-10	Off	No link is set up on the port.
		Solid green	The port operates 10/100/1000 Mbps.
		Blinking green	The port is sending and receiving traffic at 10/100/1000 Mbps.
SFP Port Link/Ack Status LED	10F	Off	No link is set up on the port.
		Solid green	The port operates at 1000 Mbps.
		Blinking green	The port is sending and receiving traffic at 1000 Mbps.

2 Preparing for Installation

2.1 Safety Precautions

Caution

- To avoid personal injury and device damage, carefully read the safety precautions before you install the device.
 - The following safety precautions may not cover all possible dangers.
-

2.1.1 Installation Safety

- Keep the chassis clean, free from any dust.
- Do not place the device in walking areas.
- During the installation and maintenance, do not wear loose clothes, ornaments, or any other things that may be hooked by the device.
- Cut off all the power supplies and unplug all power cords before placing the device in a rack or removing the device from a rack.

2.1.2 Handling Safety

- Avoid handling the device frequently.
- Keep balance and prevent personal injuries when handling the device.
- Cut off all the power supplies and unplug all power cords before moving or handling the switch.

2.1.3 Electric Safety

- Observe local regulations and specifications during electric operations. Only personnel with relevant qualifications can perform such operations.
 - Before installing the device, check whether there are hidden risks in the operating environment of the device. For example, check whether the power socket is grounded and whether the ground is wet.
 - Be sure to know the location of the indoor emergency power supply switch before installing the device. When an accident occurs, immediately cut off all power supplies.
 - Do not maintain the device by yourself when the device is powered on.
 - Make sure that the switch is powered off when you cut off the power supply.
 - Do not place the switch in a wet position, and keep the switch away from liquid.
-

Caution

- Improper or incorrect electric operations may cause a fire, electric shock, and other accidents, and lead to severe and fatal personal injury and device damage.
- Direct contact or indirect contact through wet objects with high voltage or mains power supply may be fatal.
- If the power supply system is equipped with a leakage protector (also referred to as leakage current switch or leakage current breaker), the rated leakage action current of each leakage protector must be greater than twice the theoretical maximum leakage current of all the power supplies in the system. For example, if a system is equipped with 20 identical power supplies and the leakage current of each power

supply is equal to or less than 1.5 mA, the leakage current of the system totals 30 mA. A leakage protector with 30 mA rated action current supports less than ten power supplies (that is, Action current of the leakage protector/2/Maximum leakage current of each power supply = $30/2/1.5 = 10$). In other words, the leakage protector with 30 mA rated action current supports no more than ten power supplies. In this case, the 20 power supplies in the system require at least two leakage protectors with 30 mA rated action current and each leakage protector supports ten power supplies. If power supplies in a system differ in models, the rated leakage action current of each leakage protector divided by two is greater than the sum of maximum leakage currents of all the power supplies. The rated leakage non-action current of a leakage protector shall be 50% of the leakage action current. Take a leakage protector with 30 mA rated leakage action current as an example. The rated leakage non-action current shall be 15 mA. When the leakage current is below 15 mA, the protector shall not act. Otherwise, misoperation may easily occur due to high sensitivity and thus the leakage protector trips, devices are powered off, and services are interrupted.

- To guarantee personal safety, the rated leakage action current of each leakage protector in the system must be equal to or less than 30 mA (human body safety current is 30 mA). When twice of the total leakage current of the system is greater than 30 mA, the system must be equipped with two or more leakage protectors.
- For the leakage current value of each power supply model, see the power supply model specifications in Chapter 1.

2.1.4 Electrostatic Discharge Safety

To prevent damage caused by static electricity, you must pay attention to the following:

- Ensure that the grounding screw on the rear panel of the device is tightened. Ensure that the AC power socket is a single-phase three-core power socket with protective earthing conductors (PE).
- Keep the indoor installation environment clean and free of dust.
- Keep the indoor humidity within a certain range.

2.1.5 Laser Safety

A device with an optical port usually supports multiple types of optical transceivers, all of which are Class I laser products. Pay attention to the following during the use of optical transceivers:

- When an optical transceiver is in operation, ensure that its port is connected to an optical fiber or covered by a dust cap to keep out dust and prevent it from burning your eyes.
- When an optical transceiver is in operation, do not look into its port after removing the optical fiber. Doing so may result in eye injury.

Figure 2-1 Laser Product Warning



Warning

Do not approach or look directly into any optical port under any circumstances. This may cause permanent damage to your eyes.

2.2 Installation Environment Requirements

To ensure the normal operation and prolonged service life of the switch, the installation site must meet the following requirements.

2.2.1 Ventilation and Cooling Requirements

Maintain a minimum clearance of 100 mm (3.94 in.) around the switch for air circulation and ventilation. After various cables are connected, bundle the cables or place them in the patch panel to avoid blocking air inlets. Dust the device every three months to avoid blocking the ventilation openings on the housing.

2.2.2 Temperature and Humidity Requirements

To ensure the normal operation and prolonged service life of the switch, maintain an appropriate temperature and humidity in the equipment room. The machine room with too high or too low temperature and humidity for a long period may damage the switch.

- In an environment with high relative humidity, the insulating material may have poor insulation or even leak electricity.
- In an environment with too low relative humidity, the insulating strips will shrink, and static electricity is prone to occur and damage the internal circuits of the switch.
- A high ambient temperature not only deteriorates device performance but also causes various hardware faults.

The table below lists the ambient temperature and humidity requirements of RG-ES200 series switches.

Temperature	Relative Humidity
0°C-40°C	10% RH to 90% RH

Note

Requirements for ambient temperature and humidity of sampling points:

The ambient temperature and humidity of the switch are measured at the point that is 1.5 m above the floor and 0.4 m before the switch rack when there is no protective plate in front or at the back of the rack.

2.2.3 Cleanliness

Dust poses a major threat to the switch. The indoor dust can cause electrostatic adhesion when falling on the switch, causing poor contact of the metallic joint. Such electrostatic adhesion occurs more easily when the indoor relative humidity is low, not only affecting the service life of the switch, but also causing communication failure easily. The following table lists the requirements for the dust content and diameter in the machine room.

Dust	Unit	Maximum Quantity
Dust particles (diameter \geq 0.5 μm)	Particles/ m ³	$\leq 3.5 \times 10^6$
Dust particles (diameter \geq 5 μm)	Particles/ m ³	$\leq 3 \times 10^4$

Apart from dust, the salt, acid, and sulfide in the air of the machine room must meet strict requirements. These harmful substances will accelerate metal corrosion and component aging. Therefore, the machine room should be properly protected against the intrusion of harmful gases, such as sulfur dioxide, hydrogen sulfide, nitrogen dioxide, and chlorine gas. The following table lists limit values for harmful gases.

Gas	Average (mg/m ³)	Maximum (mg/m ³)
Sulfur dioxide (SO ₂)	0.3	1.0
Hydrogen sulfide (H ₂ S)	0.1	0.5
Nitrogen dioxide (NO ₂)	0.5	1.0
Chlorine gas (Cl ₂)	0.1	0.3

Note

Average refers to the average value of harmful gases measured in one week. The Maximum value is the upper limit of the harmful gas measured in one week for up to 30 minutes every day.

2.2.4 Anti-interference

The switch is susceptible to external interference by capacitive coupling, inductive coupling, electromagnetic waves, common impedance (ground) coupling, or conduction over power lines, signal lines and output lines. Note that:

- In a TN earthing system, use a 3-wire single-phase outlet that has a protective earth (PE) contact to allow the filter circuit in the device to eliminate interference from the power grid.
- The switch should be located far away from the large power radio launch pads, radar launch pads, and high-frequency large-current devices.
- Use EMI shielding such as shielded interface cables to minimize interference when necessary.
- Route interface cables only indoors to prevent signal ports from getting damaged by overvoltage or overcurrent caused by lightning strikes.

2.2.5 Grounding Requirements

A proper grounding system is the basis for stable and reliable running. It is indispensable for preventing lightning strikes and interference. Carefully check the grounding conditions at the installation site according to the grounding specifications, and complete grounding properly based on the actual situation.

Note

- Effective grounding of the switches is an important guarantee for lightning protection and interference prevention. Therefore, the switch must be properly grounded.
- The grounding wire is customer supplied.

Secure Grounding

Ensure that the rack and power distribution device are securely grounded when the switch uses the AC power supply. Otherwise, electric shock may occur when the insulation resistance between the power supply inside the switch and the chassis becomes small.

Note

- The building should provide a protective ground connection to ensure that the device is connected to a protective earth.
 - The O&M personnel should check whether the AC socket is reliably connected to the protective ground of the building. If not, the O&M personnel should use a protective earth conductor from the AC outlet protective earth terminal to the building protective earth.
 - The power socket should be installed near the device and easily accessible.
 - During the device installation, the ground connection must always be made first and disconnected last.
 - The cross-sectional area of the protective ground cable should be at least 0.75 mm² (18 AWG).
 - Install the switch by using 3-core power cords, with a minimum cross-sectional area of 0.75 mm² or 18AWG per pin.
-

Lightning Grounding

The lightning protection system of facilities is standalone, and is composed of a lightning rod, a down conductor, and a connector connected to the grounding system. The grounding system is usually used for power reference grounding and safe grounding of the rack. Lightning grounding is required only for facilities and is not required for the switch.

EMC Grounding

Grounding required for electromagnetic compatibility includes shielded grounding, filter grounding, noise and interference suppression, and level reference, which contribute to the overall grounding requirements. The resistance of the grounding cable should be smaller than 1 ohm.

The switch provides one grounding connector on the back panel, as shown in Figure 2-1.

Figure 2-2 Grounding of the Switch



2.2.6 Lightning Protection Requirements

When an AC power cord is introduced from outdoors and directly connected to the power port of the switch, the AC power port must be connected to an external lightning resistance socket to protect the switch against lightning strokes. The lightning resistance socket is used as follows: Connect the mains AC power cable to the lightning resistance socket and then connect the switch to the lightning resistance socket. This prevents the current of high-voltage lightning from directly passing through the switch along the mains cable.

i Note

- Surge arrestors are customer supplied.
 - For details of surge arrestors, see the related user guide.
-

2.2.7 EMI Requirements

All electromagnetic interference (EMI) sources, either from outside or inside of the device or application system, affect the device by capacitive coupling, inductive coupling, or electromagnetic waves.

EMI occurs due to radiation or conduction, depending on the transmission path.

When the energy, often radio energy, from a component arrives at a sensitive component through space, the energy is known as radiated interference. The interference source can be both a part of the interfered system and a completely electrically isolated unit. Conducted interference occurs when interference is transferred from one unit to another through cables which are usually electromagnetic wires or signal cables connecting the source and the sensor. Conducted interference often affects the power supply of the switch, but this can be controlled by a filter. Radiated interference may affect any signal path in the equipment, and is difficult to shield.

- Interference prevention measures should be taken for the power supply system.
- Keep the grounding device of the switch far away from the grounding device and lightning grounding device of the power equipment.
- Keep the switch far away from the high-power radio transmitter, radar launch pad, and high-frequency large-current devices.
- Take electromagnetic shielding measures when necessary.

2.3 Tools

Table 2-1 Tools

Common Tools	Phillips screwdriver, slotted screwdriver, related copper and fiber-optic cables, bolts, diagonal pliers, cable ties
Special Tools	ESD tools
Meters	Multimeter

i Note

The RG-ES210GS-P switch is delivered without a tool kit. Customers need to get ready the tools.

3 Installing the Switch

Note

- Before reading chapter 3 "Product Installation", ensure that you have read chapter 2 carefully.
- Verify that requirements described in chapter 2 have been met.

3.1 Installation Procedure

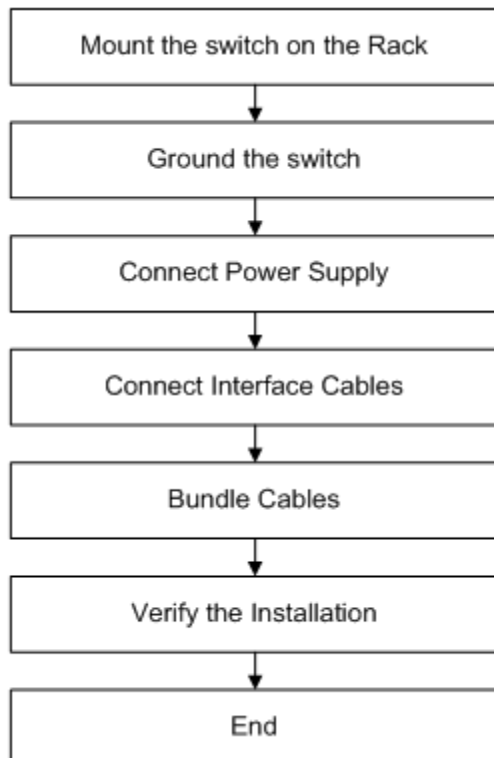

3.2 Before You Begin

Confirm the following requirements before installation:

- The installation environment meets heat dissipation requirements.
- The installation environment meets the temperature and humidity requirements.
- The power supply and required current are available in the installation site.
- Ethernet cables have been deployed at the installation site.

3.3 Installing the Switch

Precautions

Pay attention to the following:

- Connect the power cords of different colors to the corresponding cable terminals.
- Ensure that the connector of the power cord is properly seated in the power port of the switch. After the power

cord is securely inserted into the device, fasten the power cord with power cord retention clips.

- Do not place anything on the top of the switch.
- Maintain a minimum clearance of 100 mm (3.94 in.) around the device to ensure proper airflow. Do not stack switches.
- Keep the switch away from high-power radio launch pads, radar launch pads, and high-frequency large-current devices. Take electromagnetic shielding measures to minimize interference when necessary, for example, use shielded interface cables.
- Manage Ethernet cables with a distance of 100 meters (328.08 feet) indoors. Take lightning protection measures if they need to be routed outdoors.

3.3.1 Mounting the Switch on the Wall

RG-ES210GS-P can be mounted on a wall. (Screws and wall anchors for installation are not provided, and needs to be purchased by the customer).

When installing the switch, drill two holes on the wall based on the size and depth of the screws and wall anchors. Make sure that the holes are large enough to accommodate the wall anchor, with only the outer edge visible outside the wall. Additionally, ensure that the screws can be firmly fastened to the wall.

Step 1. As shown in the following figure, first drill two holes with a diameter of about 5mm on the wall, with a spacing of 112.6 mm between the two holes. Make sure that the two holes are horizontally aligned.

Step 2. Insert one wall anchor into each hole. Make sure the outer edge of the wall anchor is level with the wall surface.

Step 3. Insert one M4 screw into each wall anchor. The distance between the inner side of the screw head and the outer edge of the wall anchor must not be less than 2.5mm to ensure that the switch can be securely hung on the screw.

Step 4. Align the two holes on the chassis with the screws, and hang the switch securely on the screws.

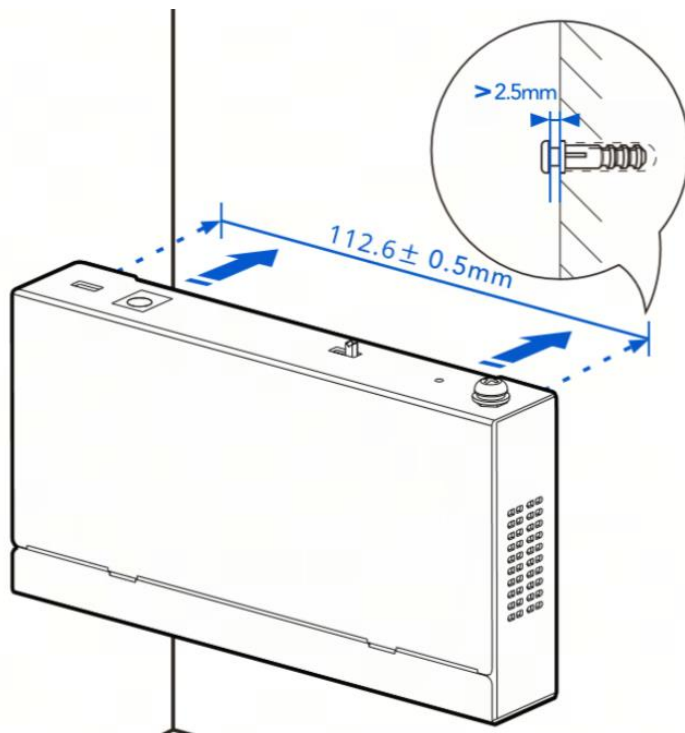
Figure 3-1 Mount the Switch on the Wall

Note: When the device is mounted on a wall, it is only suitable to be mounted on a concrete or non-flammable surface.

3.3.2 Installing the Switch on a Workbench

The switch can be mounted on a clean workbench, as shown in the following figure. The location where the switch is installed must be subject to movement restrictions.

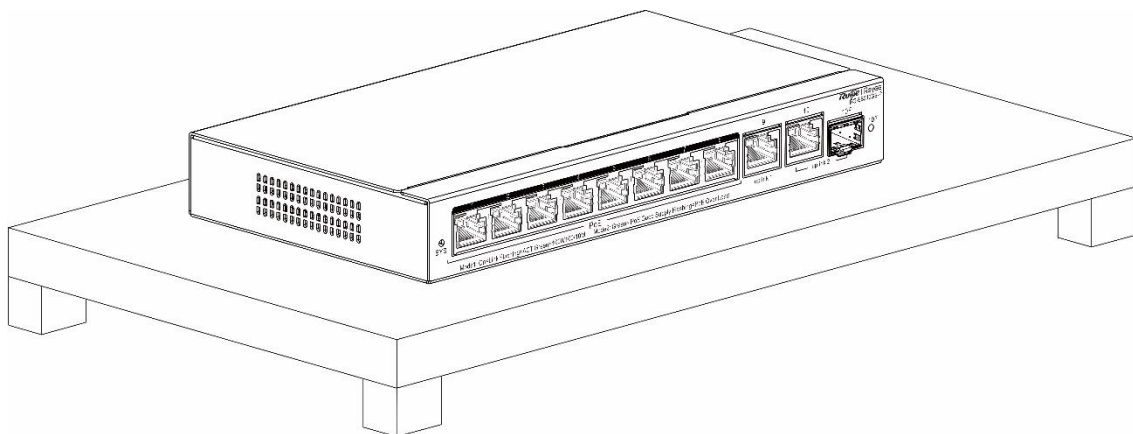

3.4 Verifying Installation

⚠ Caution

Turn off the power to avoid personal injury and damage to components caused by incorrect connection.

- Verify that the ground wire is connected.
- Verify that the Ethernet cables and power cords are properly connected.
- Verify that the cables with a distance of 100 meters (328.08 feet) are managed indoors. If not, check whether the power supply and interfaces are protected from lightning strikes.
- Verify that there is a minimum clearance of 100 mm (3.94 in.) around the switch.

4 Debugging

4.1 Powering On the Equipment

- (1) Checklist Before Power-On
 - Verify that the switch is properly grounded.
 - Verify that the power cord is properly connected.
 - Verify that the power supply voltage meets the requirement of the switch.
- (2) Checklist after Power-On (Recommended)
 - The LEDs of the switch are in the normal state.
 - Service ports can forward data properly.

4.2 Logging In to the Management Interface

- (1) Connect a PC to an Ethernet port on the switch through an Ethernet cable.
- (2) Set the IP address of the PC to 10.44.77.XXX (Range: 1-254, excluding 200).

Figure 4-1 Changing the IP Address

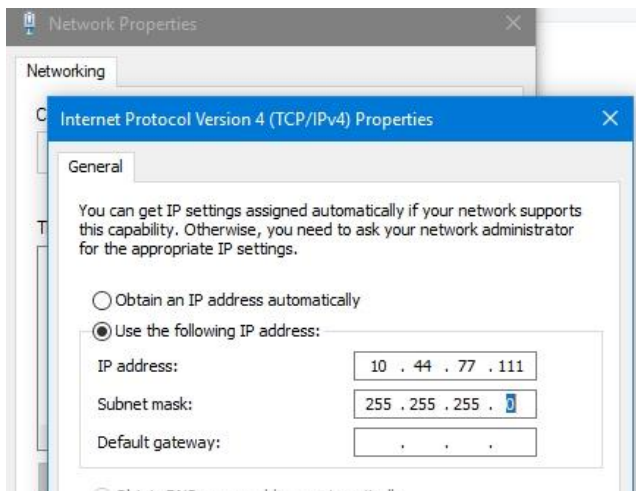

- (3) Open a browser, enter 10.44.77.200 in the address bar, and press Enter. On the login page, set a password and log in.
- (4) Perform device commissioning and configuration based on service requirements.

Note

For security purposes, you are advised to change the password regularly.

5 Common Troubleshooting

5.1 Troubleshooting Flowchart

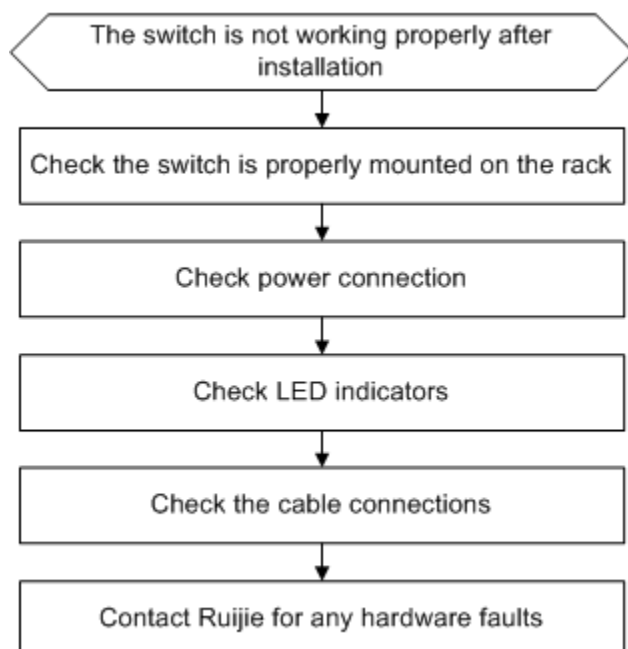

5.2 Common Troubleshooting

Fault Symptom	Possible Cause	Suggested Action
The status indicator is off after the device is powered on.	No power is supplied to the switch or the power cord is loose.	Check whether the power socket in the equipment room is normal and whether the power cable connected to the switch is loose.
An RJ45 port is disconnected or a frame sending/receiving error occurs.	The connected twisted pair cable is faulty. The cable length exceeds 100 m. The port is specially configured and does not use the same work mode as the interconnected switch.	Replace the twisted pair cable. Check port configurations and whether they work in the same mode as the interconnected switch.

Fault Symptom	Possible Cause	Suggested Action
An optical port cannot be connected.	<p>Rx and Tx ends are connected incorrectly.</p> <p>The types of the interconnected optical modules do not match.</p> <p>Fiber type does not meet requirements.</p> <p>The optical fiber length is beyond the allowed length marked on the optical module.</p>	<p>Connect the Rx and Tx ends of the fiber correctly.</p> <p>Replace optical modules with those of the same type.</p> <p>Replace the fiber with a qualified one.</p> <p>Use an optical fiber with the required length.</p>

Appendix A — Connectors and Media

1000BASE-T/100BASE-TX/10BASE-T Port

The 1000BASE-T/100BASE-TX/10BASE-T is a 10/100/1000 Mbps auto-negotiation port that supports auto MDI/MDIX Crossover.

Compliant with IEEE 802.3ab, 1000BASE-T requires Category 5e 100-ohm UTP or STP (recommended) with a maximum distance of 100 meters (328 feet).

The 1000BASE-T port requires all four pairs of wires to be connected for data transmission. Figure A-1 shows the connection of twisted pairs used by a 1000BASE-T port.

Figure A-1 Connections of Four Twisted Pairs for the 1000BASE-T Port

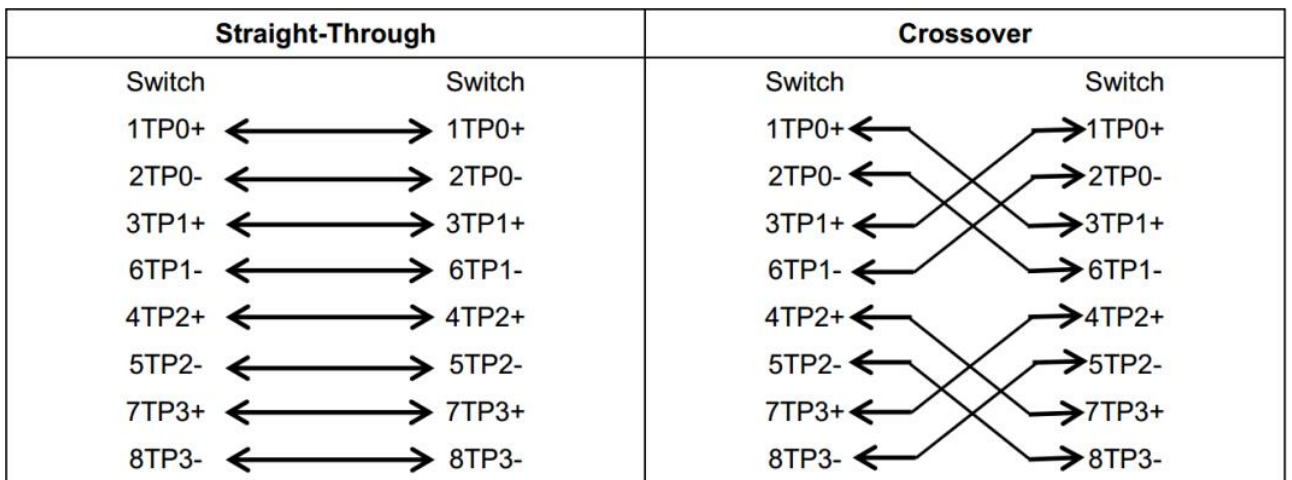

100BASE-TX/10BASE-T can be interconnected using cables of the preceding specifications. For 10 Mbps, the 100BASE-TX/10BASE-T port can be connected using 100-ohm Category 3, Category 4, and Category 5 cables; for 100 Mbps, the 100BASE-TX/10BASE-T port can be connected using 100-ohm Category 5 cables with a maximum connection distance of 100 meters. The following table shows 100BASE-TX/10BASE-T pin assignments.

Figure A-2 Pin Assignments for the 100BASE-TX/10BASE-T Port

Pin	Socket	Plug
1	Input Receive Data+	Output Transmit Data+
2	Input Receive Data-	Output Transmit Data-
3	Output Transmit Data+	Input Receive Data+
6	Output Transmit Data-	Input Receive Data-
4, 5, 7, 8	Not Used	Not Used

Figure A-3 shows feasible connections of straight-through and crossover twisted-pair cables for 100BASE-TX/10BASE-T.

Figure A-3 Twisted Pair Connections for the 100BASE-TX/10BASE-T Port

Straight-Through		Crossover	
Switch	Adapter	Switch	Switch
1 IRD+	1 OTD+	1 IRD+	1 OTD+
2 IRD-	2 OTD-	2 IRD-	2 OTD-
3 OTD+	3 IRD+	3 OTD+	3 IRD+
6 OTD-	6 IRD-	6 OTD-	6 IRD+

Optical Fiber Connection

Choose single mode or multi-mode fibers according to the module types.

Figure A-4 Optical Fiber Connection

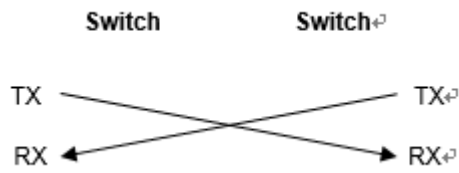

Appendix B — Mini-GBIC and SFP Modules

We provide appropriate SFP modules (Mini-GBIC modules) according to the port types. You can select the module to suit your specific needs. Besides, the Mini-GBIC-GT modules are also supported. The following models and technical specifications of some SFP modules are listed for your reference. For details about the technical specifications, see *Ruijie Transceiver Installation and Reference Guide*.

Table B-1 Models and Specifications of 1000M Mini-GBIC (SFP) Optical Modules

Model	Wave length (nm)	Cable type	DDM (Yes/No)	Intensity of Transmitted Light (dBm)		Intensity of Received Light (dBm)	
				Min	Max	Min	Max
MINI-GBIC-SX-MM850	850	MMF	No	-9.5	-3	-17	0
MINI-GBIC-LX-SM1310	1310	SMF	No	-9.5	-3	-20	-3
GE-eSFP-SX-MM850	850	MMF	Yes	-9.5	-3	-17	0
GE-eSFP-LX-SM1310	1310	SMF	Yes	-9.5	-3	-20	-3
GE-SFP-LX-SM1310	1310	SMF	No	-9.5	-3	-20	-3
MINI-GBIC-LH40-SM1310	1310	SMF	Yes	-2	3	-22	-3
GE-SFP-SX-SM1310-BIDI	1310	MMF	No	-10	-5	-17	-3
GE-SFP-SX-SM1550-BIDI	1550	MMF	No	-10	-5	-17	-3
GE-SFP-LX20-SM1310-BIDI	1310TX /1550RX	SMF	Yes	-9	-3	-20	-3
GE-SFP-LX20-SM1550-BIDI	1550TX /1310RX	SMF	Yes	-9	-3	-20	-3
GE-SFP-LH40-SM1310-BIDI	1310TX /1550RX	SMF	Yes	-5	0	-24	-1
GE-SFP-LH40-SM1550-BIDI	1550TX /1310RX	SMF	Yes	-5	0	-24	-1
MINI-GBIC-ZX50-SM1550	1550	SMF	Yes	-5	0	-22	-3
MINI-GBIC-ZX80-SM1550	1550	SMF	Yes	0	4.7	-22	-3

MINI-GBIC-ZX100-SM1550	1550	SMF	Yes	0	5	-30	-9
GE-SFP-SX	850	MMF	No	-9.5	-3	-17	0
GE-SFP-LX	1310	SMF	No	-9.5	-3	-20	-3
SFP-MM850	850	MMF	No	-9.5	-3	-17	0
SFP-SM1310	1310	SMF	No	-9.5	-3	-20	-3

Table B-2 1000Base-T SFP Copper Module

Standard	1000Base-T SFP Module	DDM (Yes/No)
1000Base-T	Mini-GBIC-GT	No

Table B-3 Cabling Specifications of SFP Modules

SFP Model	Connect or Type	Cable type	Core Specifications (µm)	Max. Cabling Distance
MINI-GBIC-SX-MM850	L/C	MMF	62.5/125	275 m
			50/125	550 m
MINI-GBIC-LX-SM1310	L/C	SMF	9/125	10 km
GE-eSFP-SX-MM850	L/C	MMF	62.5/125	275 m
			50/125	550 m
GE-eSFP-LX-SM1310	L/C	SMF	9/125	10 km
GE-SFP-LX-SM1310	L/C	SMF	9/125	10 km
MINI-GBIC-LH40-SM1310	L/C	SMF	9/125	40 km
GE-SFP-SX-SM1310-BIDI	L/C	MMF	50/125	500 m
GE-SFP-SX-SM1550-BIDI	L/C	MMF	50/125	500 m
GE-SFP-LX20-SM1310-BIDI	L/C	SMF	9/125	20 km
GE-SFP-LX20-SM1550-BIDI	L/C	SMF	9/125	20 km
GE-SFP-LH40-SM1310-BIDI	L/C	SMF	9/125	40 km
GE-SFP-LH40-SM1550-BIDI	L/C	SMF	9/125	40 km
MINI-GBIC-ZX50-SM1550	L/C	SMF	9/125	50 km
MINI-GBIC-ZX80-SM1550	L/C	SMF	9/125	80 km
MINI-GBIC-ZX100-SM1550	L/C	SMF	9/125	100 km
GE-SFP-SX	L/C	MMF	62.5/125	275 m

			50/125	550 m
GE-SFP-LX	L/C	SMF	9/125	10 km
Mini-GBIC-GT	RJ45 Ethernet cable	Cat 5 (or higher) twisted-pair cable		100 m

Note

- For optical transceivers with a maximum cabling distance of over 40 km (including 40 km), install an optical attenuator to avoid overload when using short-distance SMFs.
- An optical module is a laser transmitter. Do not look directly into the optical module to prevent it from burning your eyes.
- To keep the optical module clean, ensure that the unused ports remain capped.
- No additional cable needs to be connected when an SFP cable is used. You need to only plug both ends of the SFP cable into the corresponding ports of the switch.

Table B-4 Pairing Models of the BIDI Optical Modules

Speed/Distance	Pairing Model
1000 Mbps/500 m	GE-SFP-SX-SM1310-BIDI GE-SFP-SX-SM1550-BIDI
1 Gbps/20 km	GE-SFP-LX20-SM1310-BIDI GE-SFP-LX20-SM1550-BIDI
1 Gbps/40 km	GE-SFP-LH40-SM1310-BIDI GE-SFP-LH40-SM1550-BIDI

Note

The BIDI modules must be used in pairs. For example, if you install the GE-SFP-LX20-SM1310-BIDI in the local port, you must install the GE-SFP-LX20-SM1550-BIDI in the peer port.

Appendix C — Lightning Protection

Installing an AC Power Arrester (Lightning Resistance Socket)

When an AC power cord is introduced from outdoors and directly connected to the power port of the switch, the AC power port must be connected to an external lightning protection power strip to protect the switch against lightning strokes. The lightning resistance socket can be fixed on the rack, workbench, or wall in the machine room by using cable ties and screws. AC power enters the lightning protection power strip and then enters the switch.

Figure C-1 Power Arrester

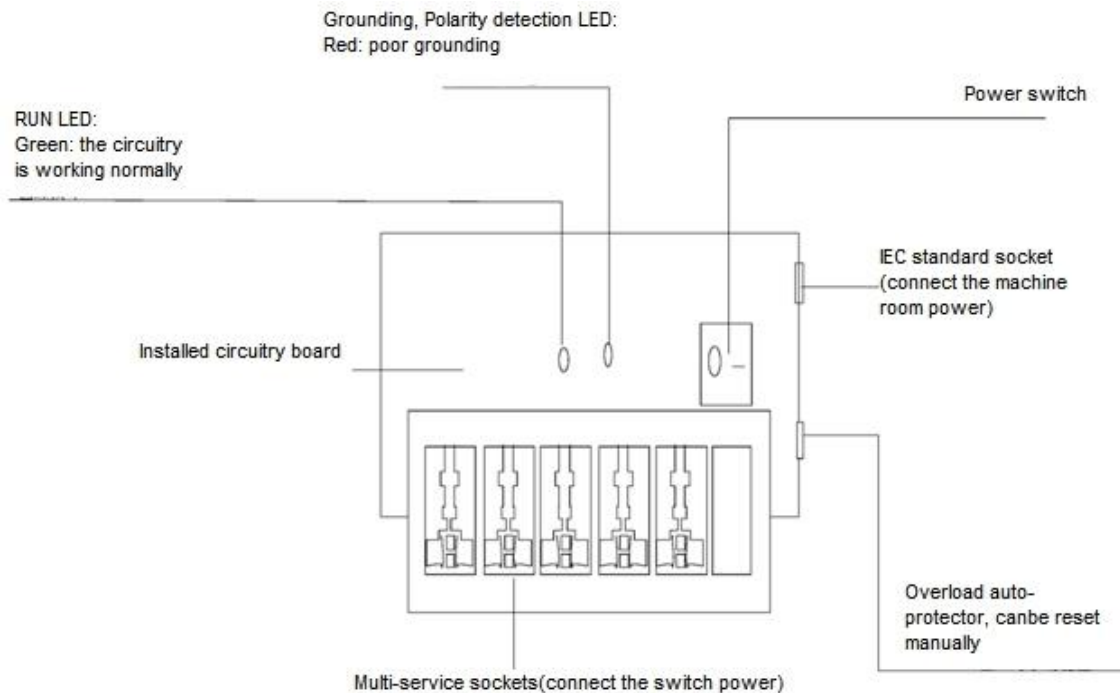

Note

The power arrester is not delivered with the switch. Please purchase it based on actual requirements.

Important points:

- Make sure that the PE terminal of the power arrester is well grounded.
- After the AC power plug of the switch is connected to the socket of the power arrester (lightning resistance socket), the lightning protection function is implemented only if the RUN indicator is green and the ALARM indicator is OFF.
- If the ALARM indicator on the power arrester is red, check whether it is caused by poor grounding connection or by the reversed connection of the Null and Live lines. The detection method is as follows: Use a multimeter to measure the polarity of the power socket for the arrester when the indicator is red. If the N line is on the left and the L line is on the right (facing the socket), the arrester's PE terminal is not grounded. If not, the polarity of the arrester power cord should be reversed. In this case, you should open the power arrester and rectify the polarity of the connection. If the indicator is still red, the arrester's PE terminal is not grounded.

Installing the Ethernet Port Arrester

Connect an Ethernet port arrester to the switch to prevent the damage by lightning before connecting an outdoor network cable to the switch.

Tools: Phillips screwdrivers or flat-head screwdriver, multimeter, and diagonal pliers

Installation Steps:

- (1) Tear one side of the protective paper for the double-sided adhesive tape and paste the tape to the enclosure of the Ethernet port arrester. Tear the other side of the protective paper for the double-sided adhesive tape and paste the Ethernet port arrester to the switch enclosure. The paste position for the Ethernet port arrester should be as close to the grounding terminal of the switch as possible.
- (2) According to the distance between the switch grounding terminal and the Ethernet port arrester, cut the grounding cable for the Ethernet port arrester and firmly crimp the grounding cable to the grounding terminal of the switch.
- (3) Use a multimeter to check whether the grounding cable for the arrester is in good contact with the grounding terminal and the enclosure of the switch.
- (4) Connect the arrester by using an adapter cable (note that the external network cable is connected to the IN end, while the adapter cable connected to the switch is connected to the OUT end) and check whether the service module LED is normal.
- (5) Use a nylon cable tie to bind the power cords.

Figure C-2 Installation of the Ethernet Port Arrester

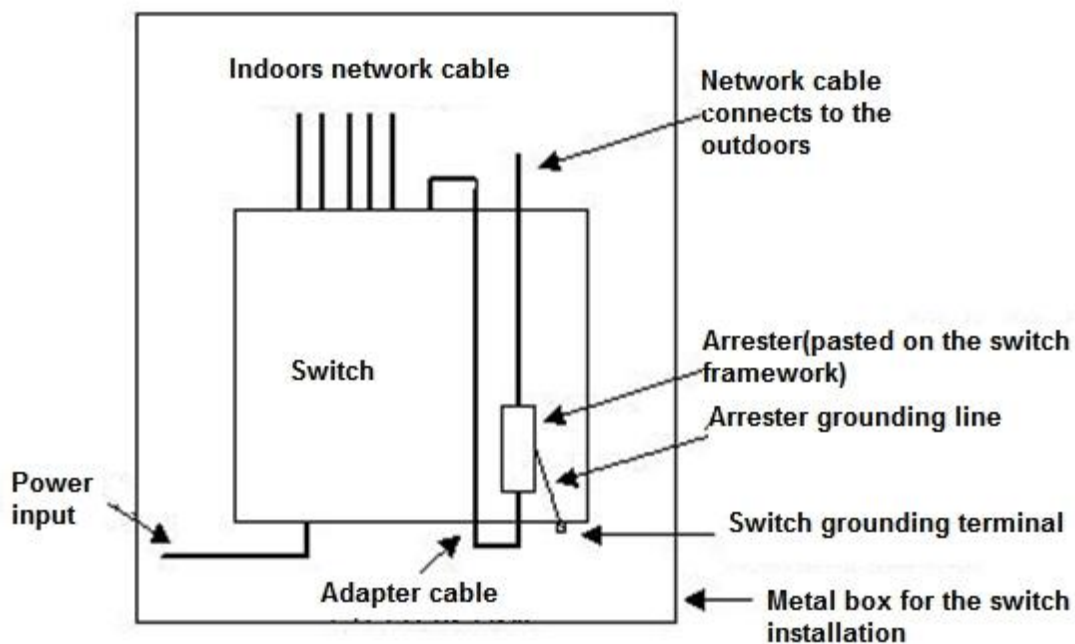

Note

- The Ethernet port arrester is only for the 10/100 Mbps copper ports with an RJ-45 connector.

- The Ethernet port arrester is not delivered with the switch. Please purchase it based on actual requirements. The Ethernet port arrester user manual contains technical parameters and maintenance and installation instructions for the Ethernet port arrester. Carefully read this manual before installation.
-
- Pay attention to the following situations during the actual installation to avoid influencing the performance of the Ethernet port arrester:
 - Reversed installation direction of the arrester. Connect the external network cable to the "IN" end and connect the Ethernet port of the switch to the "OUT" end.
 - Poor grounding of the arrester. The grounding cable of the arrester should be as short as possible to ensure that it is in good contact with the grounding terminal of the switch. Use a multimeter to confirm the contact condition after grounding.
 - Incomplete arrester installation. If there is more than one port connected to the peer device on the switch, arresters need to be installed on all connection ports for the purpose of lightning protection.

Appendix D — Cabling Recommendations

When the switch is installed in a standard 19-inch rack, secure the cables around the cable management brackets. Adopt top cabling or bottom cabling according to the actual situation in the machine room. All cable connectors used for transit should be placed at the bottom of the cabinet rather than be exposed outside of the cabinet. Power cords are routed beside the cabinet, and top cabling or bottom cabling is adopted according to the actual situation in the equipment room, such as the positions of the DC power distribution box, AC socket, or lightning protection box.

Requirements for Cable Bend Radius

- The bend radius of a fixed power cord, network cable, or flat cable should be over five times greater than their respective diameters. The bend radius of these cables that are often bent or plugged should be over seven times greater than their respective diameters.
- The bend radius of a fixed common coaxial cable should be over seven times greater than its diameter. The bend radius of the common coaxial cable that is often bent or plugged should be over 10 times greater than its diameter.
- The bend radius of a fixed high-speed cable (such as SFP+ cable) should be over five times greater than its diameter. The bend radius of the fixed high-speed cable that is often bent or plugged should be over 10 times greater than its diameter.
- Requirement for the Minimum Bend Radius of an Optical Fiber
- The diameter of a fiber tray to hold fibers should be over 25 times greater than the diameter of the fiber.
- When an optical fiber is moved, the bend radius of the fiber should be over 20 times greater than the diameter of the fiber.
- During cabling of an optical fiber, the bend radius of the fiber should be over 10 times greater than the diameter of the fiber.

Precautions for Bundling up Cables

- Before cables are bundled, mark labels and stick the labels to cables wherever appropriate.
- Cables should be neatly and properly bundled in the rack without twisting or bending, as shown in Figure D-1.

Figure D-1 Binding Cables (1)

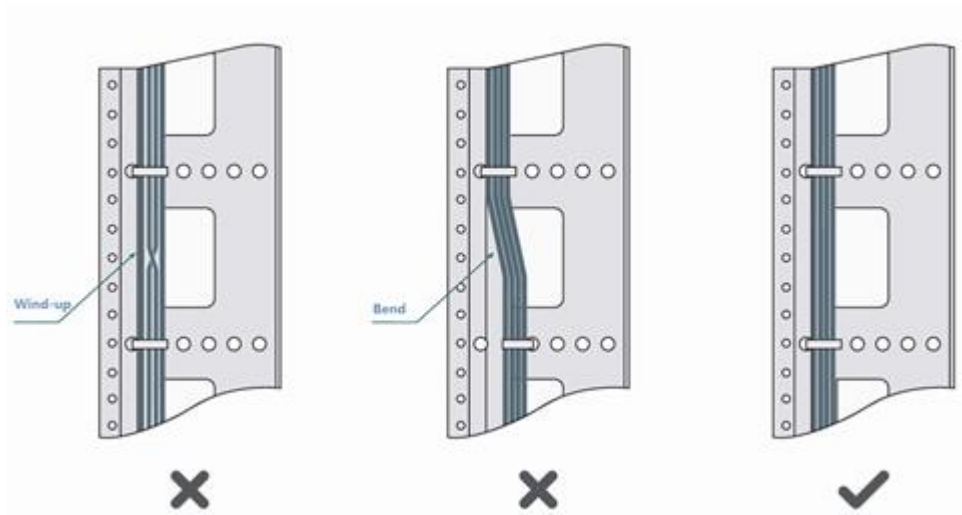

- Cables of different types (such as power cords, signal cables, and ground cables) should be separated in cabling and bundling. Mixed bundling is disallowed. When they are close to each other, you are advised to adopt crossover cabling. In the case of parallel cabling, maintain a minimum distance of 30 mm (1.18 in.) between power cords and signal cables.
- The cable management brackets and cabling troughs inside and outside the rack should be smooth without sharp corners.
- The metal hole traversed by cables should have a smooth and fully rounding surface or an insulated lining.
- Use cable ties to bundle up cables properly. Please do not connect two or more cable ties to bundle up cables.
- After bundling up cables with cable ties, cut off the remaining part. The cut should be smooth and trim, without sharp corners, as shown in Figure D-2.

Figure D-2 Binding Cables (2)

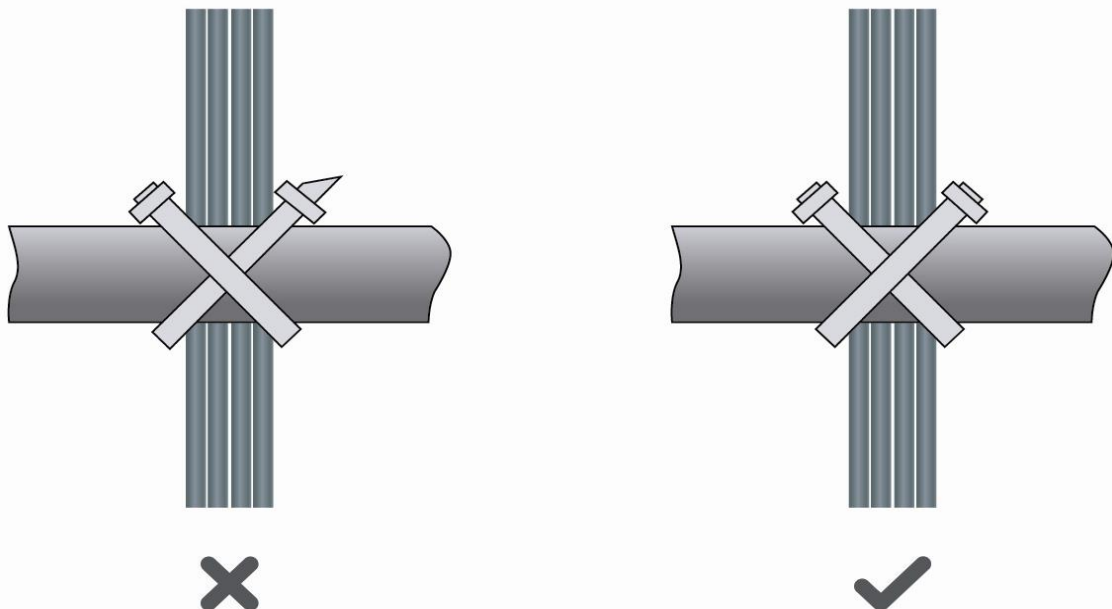

When cables need to be bent, please bundle them up but do not tie cable them where the cables will be bent, as shown in Figure D-3.

Figure D-3 Binding Cables (3)

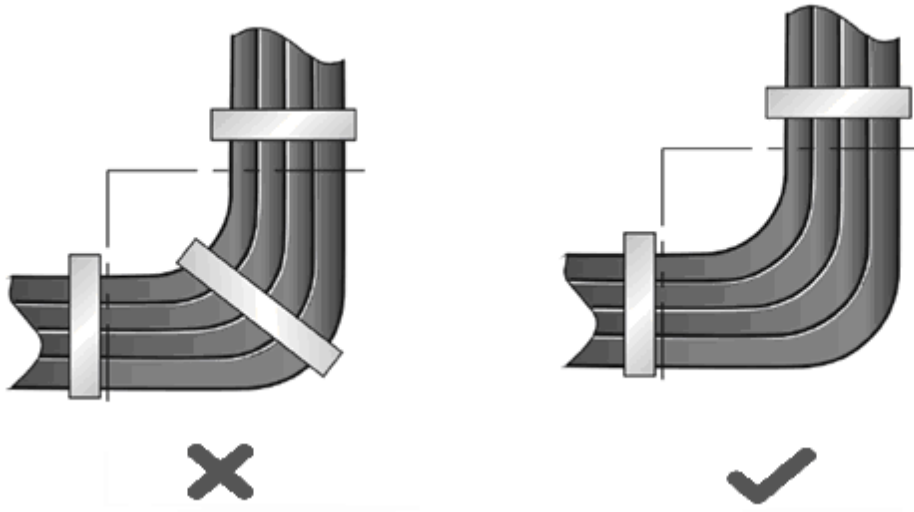

- Cables not to be assembled or remaining parts of cables should be folded and placed in a proper position of the rack or cable trough. The proper position refers to a position that does not affect device running or damage the switch or cable.
- Do not bind power cords to the guide rails of moving parts.
- The power cords connecting moving parts such as door grounding cables should be reserved with some access after being assembled to avoid suffering tension or stress. After the moving part is installed, the remaining cable part should not touch heat sources, sharp corners, or sharp edges. If heat sources cannot be avoided, high-temperature cables should be used.
- When screw threads are used to fasten cable terminals, the anchor or screw must be tightly fastened, as shown in Figure D-4.

Figure D-4 Cable Fastening

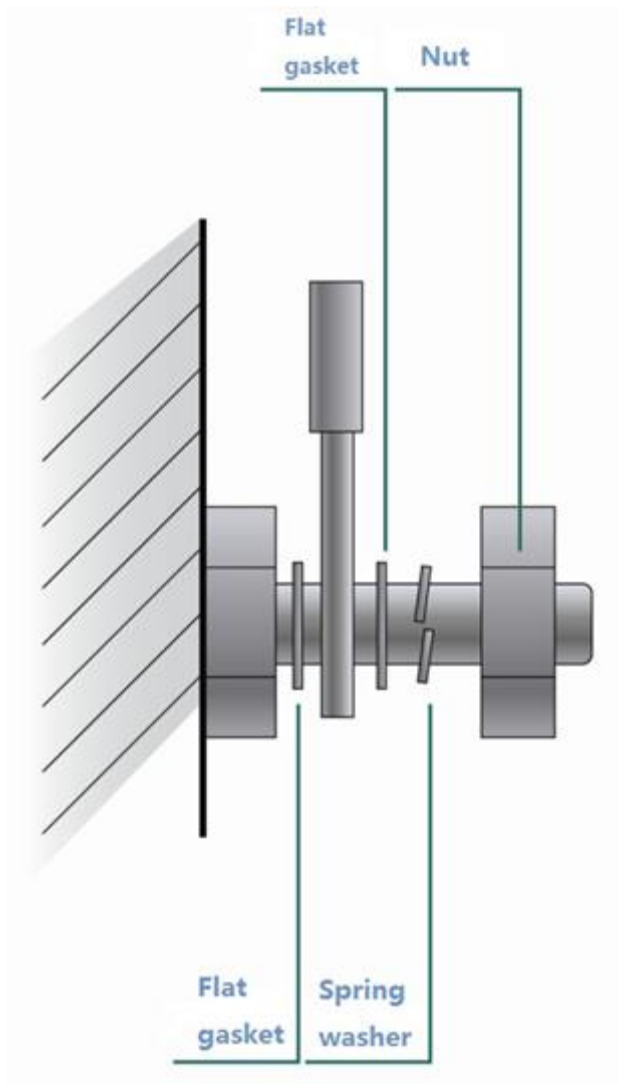

- Hard power cords should be fastened in the terminal connection area to prevent stress on terminal connection and cable.
- Do not use self-tapping screws to fasten terminals.
- Power cords of the same type and in the same cabling direction should be bundled up into cable bunches, with cables in cable bunches clean and straight.
- Bundle up cables by using cable ties.

Cable Bunch Diameter (mm)	Binding Spacing (mm)
10	80–150 mm (3.15–5.91 in.)
10–30 mm (0.394–1.18 in.)	150–200 mm (5.91–7.87 in.)
30	200–300 mm (7.87–11.81 in.)

- Do not tie cables or bundles in a knot.
- For wiring terminal sockets (such as circuit breakers) with cord end terminals, the metal part of the cord end terminal should not be exposed outside the terminal socket when assembled.

Appendix E — Machine Room Site Selection

- The machine room should be at least 5 km (3.11 miles) away from heavy pollution sources, such as the smelter works, coal mine, and thermal power plant. The machine room should be at least 3.7 km (2.30 miles) away from medium pollution sources, such as the chemical factory, rubber factory, and electroplating factory. The machine room should be at least 2 km (1.24 miles) away from light pollution sources, such as the food factory and leather plant. If the pollution source is unavoidable, the machine room should be located on the windward side of the pollution source perennially with advanced protection.
- The machine room should be at least 3.7 km (2.30 miles) away from the sea or salt lake. Otherwise, the machine room must be sealed, with air conditioner installed for temperature control. Saline soil cannot be used for construction. Otherwise, you should select devices with advanced protection against severe environment.
- Do not build the machine room in the proximity of livestock farms. Otherwise, the machine room should be located on the windward side of the pollution source perennially. The previous livestock house or fertilizer warehouse cannot be used as the machine room.
- The machine room should be firm enough to withstand severe weather conditions such as windstorm and heavy rain as well as away from dust. If the dust is unavoidable, keep the door and window away from the pollution source.
- The machine room should be away from the residential area. Otherwise, the machine room should meet the construction standard in terms of noise.
- Make sure the air vent of the machine room is away from the sewage pipe, septic tank, and sewage treatment tank. Keep the machine room under positive pressure to prevent corrosive gas from entering the machine room to corrode components and circuit boards.
- Keep the machine room away from industrial boiler and heating boiler.
- The machine room should be on the second floor. Otherwise, the machine room floor should be 600 mm (23.62 in.) higher than the highest flood level ever recorded.
- Make sure there are no cracks or holes in the wall and floor. If there are cable entries in the wall or window, take proper sealing measures. Ensure that the wall is flat, wear-resistant, and dust-free, which should be up to the standard for flame retarding, soundproofing, heat absorption, dust reduction, and electromagnetic shielding.
- Keep the door and the window closed to make the machine room sealed.
- The steel door is recommended for soundproofing.
- Sulfur-containing materials are forbidden.
- Keep the air conditioner from blowing wind straight toward the device or blowing water drops from the window or air vent toward the device.