

SPECIFICATIONS

Model No.	SLM-0001
Supply Voltage V (AC)	230
Supply Frequency (Hz)	50/60 +/- 0.5Hz
Voltage Tolerance	+/-10%
Rated Current (A)	2.0
Rated Operating Duration (on/off) minutes	15/120
Rated Temperature (°C)	-30°/+40°
Ingress Protection (EN60529)	IP65
Frequency (Hz)	1800
Maximum sound output level @ 1m	120 dB(A)
Weight (Kg)	1.8

DIMENSIONS

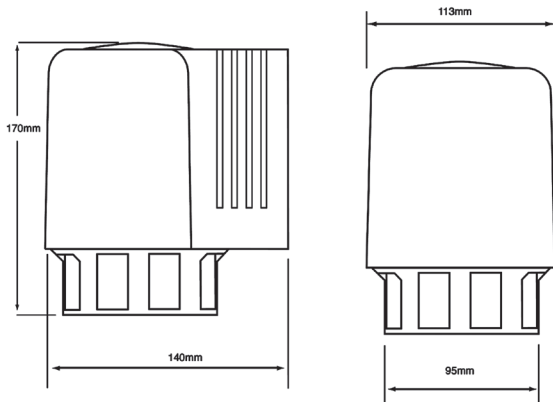

NOTE: The Master Blaster siren is only suitable for installations with a security or fire system control panel that provides a DC trigger signal.

IMPORTANT

The unit should be fitted with a fused spur incorporating an all pole disconnection device providing 3mm contact separation in all poles.

Ensure the fused spur is fitted with the 5 amp fuse supplied.

Isolate the unit from the electricity supply before removing the cover.

WARNING: No user serviceable parts contained within the unit.

WARNING: The siren generates very high sound levels. Unprotected exposure could lead to permanent hearing damage. Ensure appropriate hearing protection is used when working in close proximity to the siren.

WARNING: The siren contains rotating parts. Mount the unit at least 1.5m clear of normally accessible areas. Keep hands well clear of the siren when in operation.

The siren will operate in any orientation and may be mounted on any flat surface or conduit box. Ensure that airflow around the rotating impellor is not impaired.

NOTE: If the unit is to be used outdoors, or where water may drip onto it, the siren must be mounted with the impellor downwards, and should only be sited in sheltered locations not directly exposed to the effects of adverse weather conditions. A functional earth terminal is provided on the bracket for connection to the earth supply. The siren is double insulated and should not be earthed.

INSTALLATION

Loosen the two retaining screws and slide the bracket out of its retaining slots. Position the bracket on the surface required, allowing enough space above the final position for the movement of the siren during assembly.

A “keyhole” slot is provided to assist in vertical mounting of the bracket.

Select two diagonally opposite fixing holes of the four provided. (The other two are provided for fitting to a horizontal or vertical conduit box).

Mark their position, drill as required (including a 20mm hole if the cables are to pass through the wall) and fix the bracket. Connect to the supply earth if required.

Offer the siren into position, passing the cables through the wall or through the triangular aperture between the bracket and the siren – left or right as required – and engage the retaining slots onto the bracket and slide into position.

Tighten the retaining screws and complete the wiring.

The brown and blue cores should be connected to a 5 A fused AC supply.

BROWN – LIVE BLUE – NEUTRAL.

The twin flex is connected to the D.C supply that is to control the operation of the siren i.e. the alarm bell circuit of a security system or sounder circuit of a fire system. The D.C supply should be connected as follows:

WHITE – POSITIVE

WHITE WITH A BLACK STRIPE – NEGATIVE.

The siren is protected against reverse polarity connection and the relay will not operate if wrongly connected.

OPERATION

Connect the permanent AC supply. The siren will activate when the appropriate trigger voltage is applied the trigger input.

Fuse rating: 5A



The European directive “Waste Electrical and Electronic Equipment” (WEEE) aims to minimise the impact of electrical and electronic equipment waste on the environment and human health. To conform with this directive, electrical equipment marked with this symbol must not be disposed of in European public disposal systems. European users of electrical equipment must now return end-of-life equipment for disposal. Further information can be found on the following website: <http://www.recyclethis.info/>.