

Contemporary Keypad

Partcode: EUR-064

RINS1021-12



EN50131-3:2009
EN50131-1:2006+A1:2009
PD6662:2010
Security Grade (SG) 3
Environmental Class (EC) II

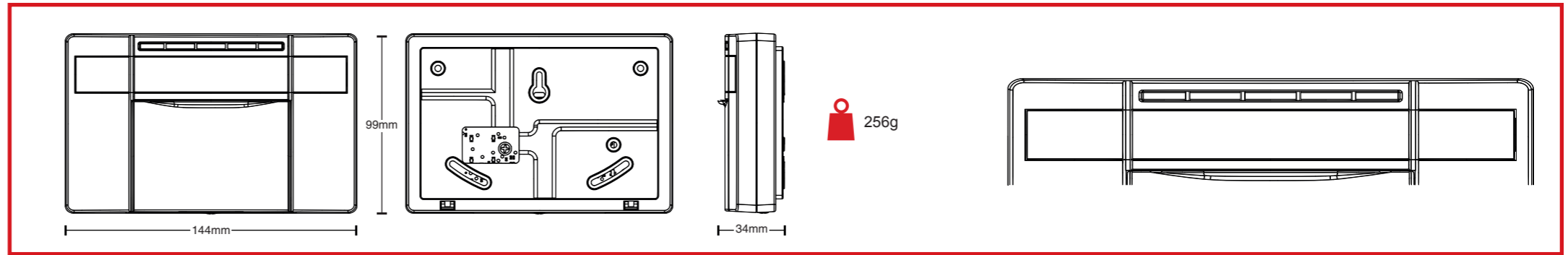

EN

Status LEDs



Proximity Reader

The proximity reader is located to the left of the LCD screen. When a proximity tag is presented, a 'beep' should be heard from the keypad.

Installation

Perform steps 1 to 3. Insert a screw to secure the back tamper, as in step 4. Replace the front as in step 5. Make sure to remove the protective covers from the tag reader LED diffuser and LCD screen as in step 6. Fit the keypad window as in steps 7 and 8 making sure to remove the protective films whilst fitting.

Please note: Keypads/proximity readers should not be mounted on a metal surface, or be located within 1m from each other. Loudspeakers also should not be located within 1m from a keypad/tag reader as the tag reader response will degrade.

Keypad configuration

Press and hold 'D' for 5 seconds. Enter '2000' to display the Address screen. Enter a unique address for the keypad. Press 'YES' to choose more settings or press 'A' to exit. Refer to the control panel manual for instructions on how to enable the keypad. This can be found in the section 'ASSIGN KEYPADS/READERS?'

Keypad PCB Layout

Adjust the potentiometer to alter screen contrast if required however this should be preset in the factory to the best viewing. Make sure the spring is securely fitted to the tamper switch.

Wiring

The keypad must be wired to the 485 bus on the panel to operate. Two inputs can also be wired to the keypad terminals at 'Z1' and 'Z2'. The PGM terminal by default is a 16ohm speaker output however when programmed becomes a transistorised output which is negative applied.

Specifications

Device colour White	Indication LEDs Amber, red and green	Storage temperature -10°C to +40°C
Casing 3mm ABS	Operating voltage 9-15V DC	Operating temperature -10°C to +40°C
Dimensions 144 x 99 x 34mm	Current consumption < 50mA	
EN50131 Certified Grade 3	Output rating PGM - 100mA (or 16ohm speaker)	
Tamper switches Front and rear		

Product information

Applies to electrical products sold within the European community. At the end of the electrical product's life, do not dispose of it with household waste. Where possible, recycle the product. Check with your Local Authority or retailer for recycling advice in your country.

Warranty

This product is sold subject to our standard warranty conditions and is warranted against defects in workmanship for a period of two years. In the interest of continuing care and design, Pyronix Ltd reserves the right to amend specifications without giving prior notice.

